



# LA COLLECTION

VOL. VIII

**IN&OUTDOOR LIFESTYLE**





**FAIT DANS LES RÈGLES DE L'ART  
DEPUIS PLUS DE TRENTE ANS**

*MADE IN THE STATE OF THE ART  
FOR MORE THAN THIRTY YEARS*



# MAIORI

## ACTEUR DE L'ART DE VIVRE

PROVIDER OF GOOD LIVING

Fondée en 1989, Maiori conçoit, fabrique et commercialise des meubles d'extérieur et des lampes solaires dans un style polyvalent, convivial et novateur.

### LES VALEURS

Chaque pièce MAIORI est conçue autour de la durabilité dans une optique éco-responsable.

Les produits sont soumis à des tests de qualité exigeants afin d'assurer leur pérennité, quelles que soient les conditions météorologiques.

*Established in 1989, we are designers, makers and editors of smart, sustainable outdoor furniture and solar lighting that is versatile, user friendly and innovative.*

### DESIGN VALUE

*Every MAIORI piece must be designed around sustainability with an eco-responsible approach.*

*We put our furnitures through the most demanding quality tests to ensure they serve its purpose for long time, no matter what weather conditions.*

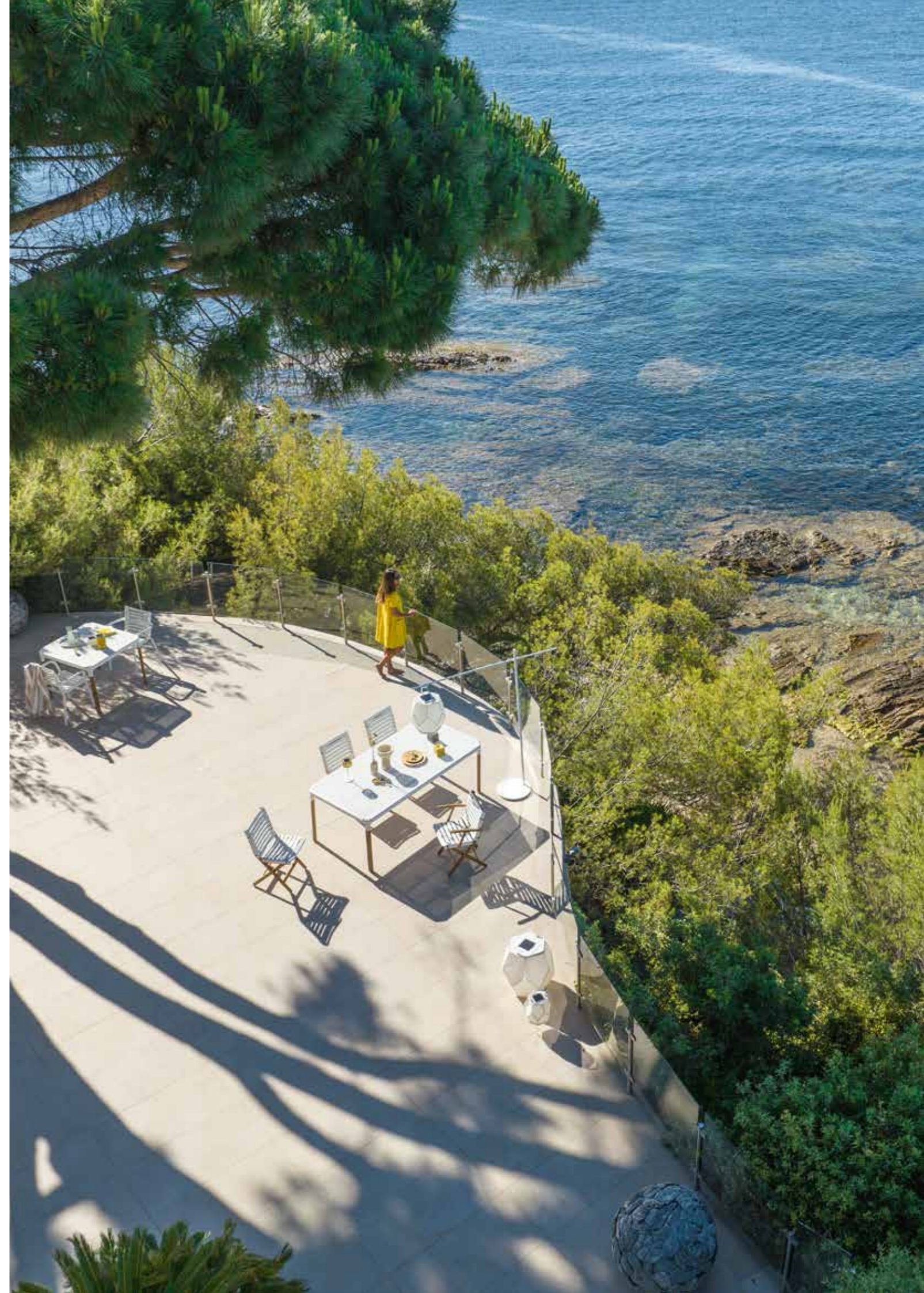

# INDEX

- 08 • La Collection en un clin d'œil / *MAIORI Collection at a glance*
- 14 • L'esprit MAIORI / *Maiori spirit*
- 20 • La création industrielle / *Industrial design*
- 22 • L'éco-responsabilité / *Eco-responsible*
- 24 • Les Maestros du design / *Design maestros*

## 26 • Collection LA LAMPE MAIORI

- 30 • La Lampe / *Technologies*
- 34 • La Lampe Paris
- 38 • La Lampe Padere
- 40 • La Lampe Parabole
- 42 • La Lampe Passage
- 44 • La Lampe Parc
- 48 • La Lampe Petite
- 50 • La Lampe Pacha
- 52 • La Lampe Couture
- 56 • La Lampe Paillote
- 58 • La Lampe Pose 01
- 60 • La Lampe Pose 02
- 62 • La Lampe Pose Mini
- 64 • La Lampe Pose 04
- 66 • La Lampe Pop Up
- 68 • La Lampe Guirlande
- 70 • Les porte lampes
- 72 • Les accessoires

## MATIÈRES & COULEURS

- 174 • Aluminium
- 176 • Teck / *Teak*
- 178 • OTF
- 180 • Fibres synthétiques / *Synthetic fibers*
- 182 • Toiles / *Canvas*
- 184 • MAIORI dans le monde / *A global reach*
- 190 • Informations techniques / *Technical informations*

## 74 • Collection LE MOBILIER MAIORI

- 76 • AT800
- 84 • Stipa
- 94 • Huggy
- 100 • Classique
- 108 • Tresse
- 112 • Idyll
- 120 • Kose
- 124 • Vega
- 132 • Initial
- 138 • A600
- 148 • Mica
- 152 • NC
- 160 • Watchair
- 162 • Light Tray
- 164 • Greens
- 168 • Le Plateau
- 170 • Les Sets de table



# LA COLLECTION

MAIORI EN UN CLIN D'OEIL

MAIORI COLLECTION AT A GLANCE

## LAMPES LAMPS

### LAMPES SUR PIED / STANDING LAMPS



La Lampe Paris  
P.36



La Lampe Padere  
P.38

### LAMPE PORTATIVE / PORTABLE LAMP



La Lampe Petite  
P.48

### LAMPES DE CHEMIN / PATHWAY LAMPS



La Lampe Passage  
P.42



La Lampe Parabole  
P.40

### LANTERNES / LANTERNS



La Lampe Couture S  
P.52

La Lampe Couture M  
P.52

La Lampe Couture L  
P.52



La Lampe Paillote S  
P.56

La Lampe Paillote M  
P.56

La Lampe Paillote L  
P.56



La Lampe Pacha  
P.50



La Lampe Parc S  
P.44

La Lampe Parc M  
P.44

La Lampe Parc L  
P.44

### LAMPES DE TABLE / TABLE LAMPS



La Lampe Pose 01  
P.58



La Lampe Pose 02  
P.60



La Lampe Pose Mini  
P.62



La Lampe Pose 04  
P.64



La Lampe Pop Up  
P.66

### PORTE-LAMPES / LAMP HOLDERS



La Lampe Couture  
P.52



La Lampe Escargot  
P.72



La Lampe Chat  
P.72



La Lampe Hibou  
P.72

### ACCESSOIRES / ACCESSORIES



La Tablette Shelf  
P.74



La Sangle Petite  
P.74



La Lampe Le Module S  
P.75



La Lampe Le Module B  
P.75



La Lampe Le Module charging tray  
P.75

# ASSISES SEATS

## CHAISES ET TABOURETS / CHAIRS & STOOLS



AT800 P.76   Stipa P.84   Huggy P.94   Vega P.124   A600 P.138   Mica P.148   NC P.152

## FAUTEUILS / ARMCHAIRS



AT800 P.76   Stipa P.84   Huggy P.94   Tresse P.108   Idyll P.114  
Kose P.122   Vega P.124   A600 P.138   Mica P.148   NC P.152

## CHAISES DE BAR / BAR CHAIRS



Stipa P.84   Huggy P.94   Vega P.124

## FAUTEUILS DE BAR / BAR ARMCHAIRS



Stipa P.84   Vega P.124

## TABOURETS / STOOLS



Stipa P.84   Huggy P.94

## CHAISES HAUTES / HIGH CHAIRS



Stipa P.84   Huggy P.94   NC P.152

## CHAISES LONGUES / SUN LOUNGERS



NC P.152

## FAUTEUILS BAS / LOW ARMCHAIRS



Stipa P.84   Idyll P.112   A600 P.138   A600 P.138   Classique P.100

## CANAPÉS ET BANCS / SOFAS & BENCHES

### CANAPÉS SOFAS



Classique P.100   Idyll P.112   A600 P.138

### BANCS BENCHES



Stipa P.84   Stipa P.84   Huggy P.94   A600 P.138

## MODULABLE / MODULAR



Classique P.100   Classique P.100   Classique P.100   Classique P.100   Classique P.100   Classique P.100



Initial P.132   Initial P.132   Initial P.132

## OTTOMANS / OTTOMANS



Stipa P.84   Classique P.100   Idyll P.112   A600 P.138   A600 P.138   Initial P.132

# TABLES

## TABLES

### TABLES - 4 PIEDS - H75 / TABLES - 4 LEGS - H75

#### CARRÉES / SQUARE



**AT800** P.76   **Stipa** P.84   **Idyll** P.112   **Tresse** P.108   **Vega** P.124   **A600** P.138   **NC** P.152

#### RECTANGLES / RECTANGULAR



**AT800** P.76   **Tresse** P.108   **Stipa** P.84   **Idyll** P.112   **Vega** P.124   **A600** P.138   **NC** P.152

#### EXTENSIONS / EXTENSIONS



**Vega** P.124   **A600** P.138

### TABLES - PIED CENTRAL - H75 / TABLES - CENTRAL LEG - H75

#### RONDES / ROUND



**Huggy** P.94   **Kose** P.120   **Vega** P.124

#### CARRÉES / SQUARE



**Kose** P.120   **Vega** P.124   **A600** P.138

### TABLES DE BAR / BAR TABLES

#### CARRÉES & RONDES - H105 / SQUARE & ROUND - H105



**Huggy** P.94   **Vega** P.124   **Vega** P.124

#### TABLES HAUTES - H90 / HIGH TABLE - H90



**NC** P.152   **NC** P.152

### TABLES BASSES / COFFEE TABLES



**Classique** P.100   **Idyll** P.112   **A600** P.138

### TABLES AUXILIAIRES / SIDE TABLES



**Classique** P.100   **NC** P.152   **Stipa** P.84

### WATCHAIR / WATCHAIR



**Single** P.160   **Double** P.160

# ACCESSOIRES

## ACCESSORIES

### JARDINIÈRES / PLANTERS



**Greens** P.164   **Greens** P.164   **Greens** P.164   **Greens** P.164   **Greens** P.164

### DESSERT / TROLLEY



**Light Tray** P.162

### PORTE-MANTEAU / COAT HANGER



**Huggy** P.94

### TABLETTE / TRAY



**Le Plateau** P.168

### SETS DE TABLE / PLACEMATS



**Placemats** P.170



**UN ESPRIT  
PIONNIER NOVATEUR**  
*INNOVATIVE VISIONARY SPIRIT*





# NOUVELLE DYNAMIQUE

A NEW DYNAMIC

Tout a commencé en 1989 à Hong Kong, à l'aube de la mondialisation. Le mur de Berlin venait de tomber et la Chine commençait à ouvrir ses frontières, générant une nouvelle dynamique économique aux dépens des anciens modèles traditionnels. Les productions étaient plus souvent sous-traitées, en particulier en Asie, ce qui officialisera et changera l'ère mondiale et, avec ce monde en mutation, les modes de vie et la consommation.

Conscient des développements actuels, Maiori pariait sur le savoir-faire et la tradition, tout cela propulsé dans une logique et une échelle industrielles globales. Le mobilier des usines de Maiori était conforme aux normes européennes et internationales. Dans le même temps, la marque a créé un département de recherche et développement au sein duquel les concepteurs pouvaient surveiller, superviser et contrôler la production de leurs objets, encourageant Maiori à concevoir ses propres meubles et à travailler avec d'autres marques.

*It all started in 1989 in Hong Kong right at the dawn of globalization. The Berlin Wall had just fallen and China began to open up its borders, boosting a new economic dynamic at the expense of older traditional models. Productions were being outsourced now, particularly in Asia, and so the global era was formalized and with this world changes, lifestyles and consumption changed too.*

*Aware of the current developments, Maiori bet was on the know-how, tradition and craftsmanship, all propelled into a global industrial scale and logic. The furniture out of Maiori's factories met European and international standards. At the same time, the brand created a Research & Development department in which designers could monitor, supervise and control the production of their objects, encouraging Maiori to design their own furniture and also to work with other brands.*

Le label Maiori était une étape naturelle vers les réalisations en matière de design de marque, qui partageait les valeurs, l'esprit et la philosophie de la maison. C'est-à-dire, qui offrait une performance de qualité à un prix abordable, sans négliger le caractère qualitatif, la création, l'innovation et la pertinence pour les canaux de distribution.

## UNE HISTOIRE, UN PRODUIT

Vingt-cinq ans plus tard, la marque a mûri. Elle a affiné sa stratégie et son identité et élargi sa gamme de produits avec l'éclairage solaire, tout en restant fidèle à ses valeurs d'origine. Maiori vit toujours dans un état d'esprit pionnier, ouvert aux talents du monde entier, un compromis avec la technologie de pointe et des valeurs de conception durables. Chaque produit de la marque raconte une histoire et vise à faciliter la vie de ses utilisateurs. L'utile prime sur la vanité, une logique que l'on retrouve même dans le parti pris de Maiori pour la protection durable et environnementale.

*Maiori label was a natural step to brand design achievements, which shared the values, spirit and philosophy of the house. That is to say, that offered a quality performance at an affordable price, without neglecting the qualitative nature, the creation, innovation and the relevance to distribution channels.*

## A STORY, A PRODUCT

*Some twenty-five years later, the brand has matured. It has refined its strategy, identity and expanded its product range with solar lighting, but remains true to its original values. Maiori still inhabits in a pioneering state-of-mind, openness to the world's talents, compromise with advanced technology and sustainable design values. Each product in the brand tells a story, and is intended to make life easier for its users. The useful overrides the vanity, a logic that is found even in the bias of Maiori for sustainable and environmental protection.*



# MAIORI DESIGN

## EN QUELQUES CHIFFRES

ABOUT US

DESSINÉ EN  
DESIGNED IN **FRANCE**

DES BUREAUX À  
OFFICES IN **HONG KONG, PARIS,  
INDONESIA & RPC**

**3** SITES DE PRODUCTION EN CHINE ET INDONÉSIE  
PRODUCTION SITES IN CHINA & INDONESIA

**30** COLLABORATEURS  
COLLABORATORS

ATELIER R&D DE  
R&D WORKSHOP **2500 m<sup>2</sup>**

**1000** CLIENTS, PARTENAIRES, DISTRIBUTEURS, REVENDEURS  
CLIENTS, PARTNERS, DISTRIBUTORS, RETAILERS

**45** INGÉNIEURS  
ENGINEERS

**40** PAYS  
COUNTRIES

MAIORI

# LA CRÉATION INDUSTRIELLE

INDUSTRIAL DESIGN

**MD Studio** est un studio de design interdisciplinaire dont les designers sont au service de la création industrielle. Ce laboratoire est aujourd'hui parmi les plus prolifiques s'agissant de la fabrication de meubles pour l'intérieur et l'extérieur, et de sa collection de Lampes solaires, hybrides et connectées. Grâce à son savoir faire innovant et à son expertise en matière de nouvelles technologies, MAIORI produit des objets intelligents et adaptables en lien étroit avec les nouveaux modes de vie soucieux de confort et de protection de la nature.

*MD Studio is an interdisciplinary design studio whose designers work in the field of industrial design. This laboratory is now one of the most prolific producers for indoor and outdoor furniture, and of solar lamp, hybrid and connected in France. Building on its innovative know-how and expertise in new technologies MAIORI produces smart and adaptable objects that reflect new lifestyle choices with a view to enhancing comfort as part of an eco friendly approach.*



# L'ÉCO

## RESPONSABILITÉ

ECO-RESPONSIBLE



**INNOVANT**  
INNOVATIVE

### UNE INNOVATION DANS L'ÉCLAIRAGE EXTÉRIEUR

- Une alimentation par le soleil
- Un éclairage puissant jusqu'à 300 lumens
- Un faible coût d'exploitation :  
La Lampe Maiori utilise les ressources de la nature, son fonctionnement est totalement vertueux et respectueux de l'environnement
- La lumière où que vous soyez : plus besoin de câble électrique, la Lampe Maiori est autonome.
- Une installation facile : sans fil, sans câblage électrique, pour un fonctionnement qui ne nécessite pas de coût supplémentaire.

### INNOVATIVE IN OUTDOOR LIGHTING

- Powered by the sun
- Powerful lighting feature until 300 lumens
- Low operation cost :  
La Lampe Maiori is powered by nature, there is no electricity or operation cost for the lamp
- Light wherever you are :  
no cable needed, La Lampe Maiori is autonomous
- Low installation cost :  
wireless, there is no complicated electricity wiring installation required. Hence no set up cost for the lamp



**RECYCLABLE**  
RECYCLABLE

### DES MATÉRIAUX DE QUALITÉ

- Aluminium 100% recyclable
- Structure du module recyclable
- Peinture écologique DuPont en poudre, sans solvant, recyclé et recyclable à 100%
- Le procédé OTF Texyloop® de Serge Ferrari, est un procédé breveté et unique qui garantit le recyclage de 100% des constituants du tissu.

### DES EMBALLAGES RECYCLABLES

- Emballage sans agrafe
- Papier recyclable
- Encre à base de soja
- Sans plastique, ni polystyrène

### HIGH QUALITY MATERIALS

- Aluminium 100% recyclable
- Recyclable module structure
- Eco-friendly DuPont Paint for powder coating which contains no solvent. 100% recycled and recyclable
- OTF Texyloop® process form Serge Ferrari : a unique patented recycling process which guarantees 100% of the fabric constituents are recycled

### RECYCLABLE MATERIALS

- Staple free carton box
- Sustainable and mixed source papers
- Soy based ink
- Plastic and polystyrene free



**DURABLE**  
SUSTAINABLE

### FABRIQUER DES OBJETS DURABLES

- Tous les matériaux sont recyclables
- Un fort respect de l'environnement :  
Le module solaire offre un système d'économie d'énergie et par conséquent une gestion tempérée des besoins en éclairage.
- Un capteur de lumière automatique : pour une utilisation rationnée, responsable et durable.

### PRODUCTION OF SUSTAINABLE PRODUCTS

- All the materials are recyclable
- Love nature :  
The solar module offers better lighting management and energy saving system
- An automatic light sensor :  
for rational, responsible and sustainable use



**ECONOMIE CIRCULAIRE**  
CIRCULAR ECONOMY

### UN SITE MODERNE ET CERTIFIÉ

- Le bureau de production Maiori est certifié ISO 14001, ce qui garantit notre engagement pour le respect de l'environnement et le développement durable
- Ligne de peinture automatique
- Soudage robotisé
- Rationalisation du processus de fabrication
- Optimisation de la consommation d'énergie par une réduction régulière de la température des fours

### A CERTIFIED AND MODERN PRODUCTION SITE

- The Maiori office is certified by ISO 14001 which ensure our commitment to environmental and sustainable development
- Automatic painting line
- Robot welding
- Streamlining manufacturing process
- Optimization of the energy consumption by monitoring the temperature of the paint ovens

# LES MAESTROS

## DU DESIGN

MAIORI DESIGN MAESTROS



### CHRISTOPHE PILLET

Designer français, Christophe Pillet est reconnu internationalement pour la diversité et la qualité de ses incursions dans l'architecture, les objets, le mobilier et la direction artistique. Son sceau est invariablement associé à de grands projets et à de prestigieuses marques : Lacoste, Jean-Claude Jitrois, Maiori, Catherine Malandrino, Lancel, Le Tanneur International.

*The lucidity of expression and the search for simplicity are the key principles : in the work of Christophe Pillet, the elegance is optimized. Pillet's perfect command of sensuality and refinement has made him one of the rare French designers who has gained global recognition designing hotels, boutiques and directing artistic projects in the USA, Great-Britain and Japan. He has won international acclaim for the spectrum and quality of his creations. Architecture, objects, furniture, artistic direction, his signature is invariably associated with the finest brands : Lacoste, Jean-Claude Jitrois, Maiori, Catherine Malandrino, Lancel, Le Tanneur International...*



### NORMAL STUDIO

En 2016, Normal Studio fête ses dix ans sur la scène française, une présence déjà remarquée par de nombreuses récompenses.

Maiori et Normal Studio collaborent depuis des années et plus particulièrement sur des projets de mobilier extérieur comme les collections AT800 et Tresse.

*In 2016, Normal Studio celebrated ten years on the French design scene, a success already recognized by numerous awards.*

*Maiori and Normal Studio have been collaborating for years on outdoor furniture lines such as AT800 and Tresse collections.*



### KARIM RASHID

Le magazine Time l'a décrit comme " le designer industriel américain le plus reconnu ". Plus de 3000 designs en production, plus de 300 prix et œuvres issus de plus de 40 pays témoignent de sa légende du design. Le travail de Karim fait partie de 20 collections permanentes et est exposé dans des galeries du monde entier. Pour Karim, " le design, cela signifie améliorer nos vies, la poésie, l'esthétique, l'expérience, les sens et les émotions ". Ainsi, Rashid exprime ses intentions, car " le désir est de voir les gens vivre dans le modus de notre temps, de participer au monde contemporain ".

*Time magazine has described Karim Rashid as the " most famous industrial designer in all the Americas ". Over 3000 designs in production, over 300 awards and working in over 40 countries attest to Karim's legend of design. Karim's work is featured in 20 permanent collections and he exhibits art in galleries worldwide. For Karim " Design is about the betterment of our lives poetically, aesthetically, experientially, and emotionally ". Rashid expresses his intentions as the "desire is to see people live in the modus of our time, to participate in the contemporary world.*



### ANTOINE LESUR

Diplômé de l'école Boule en 2002 et fort d'une expérience de dix ans en agences, Antoine Lesur crée en 2012 son propre studio de design. Il a remporté le premier prix du concours Emile Hermès en 2014.

*Exciting French talent Antoine Lesur's creations equally emanate sensitivity and technique. Graduated from the Ecole Boule in 2002 and earning strong experience in several agencies. Antoine established his own design studio in 2012. Antoine was awarded the prestigious Émile Hermès Prize in 2014.*



COLLECTION  
**LA LAMPE**



LA LAMPE COLLECTION BY MD STUDIO

# LA LUMIÈRE OÙ QUE VOUS SOYEZ

LIGHT, WHEREVER YOU ARE

**La Lampe** est une collection inspirante et autonome de lampes solaires, qui promet d'illuminer vos nuits, où que vous soyez. Créée à partir de matériaux performants et recyclables, La Lampe collection résistera aux intempéries et perdurera dans le temps. La base et les pieds sont en Aluminium haute performance, l'abat-jour en tissu conçu pour une utilisation extérieure. Le module peut être chargé avec un dock USB, il peut aussi se connecter sur l'application MAIORI par Bluetooth.

La Lampe collection puise son inspiration dans les rues historiques parisiennes. Depuis 1677, les réverbères éclairent les citadins qui flânent dans la capitale surnommée alors "Ville Lumière". Aujourd'hui La Lampe collection répond à vos attentes. Son système solaire sans fil, sa technique et son design innovant lui permettent de briller où que vous soyez.

*The solar-powered **La Lampe Collection** draws its inspiration from the historical streets of Paris. Back in 1677, to the lights of the "Réverbère" gas lamps, people flowed into the streets, earning the French capital the nickname 'city of light'. Today, La Lampe Collection brings light to wherever it is needed. Thanks to its wireless solar power module and advanced design features, La Lampe shines where most lamps can't. The Solar Hybrid module can be chargeable with the USB dock during cloudy day if necessary. It can be also connected with the MAIORI app through Bluetooth.*

*La Lampe Collection is created from high performance materials and coatings, engineered so that it will endure long periods under any weather conditions. The base and the frame are made of powder coated recyclable aluminum alloy, and the shade is cut from our renowned Batyline Fabric.*



# MAIORI

## LEADER DE LA LAMPE SOLAIRE HYBRIDE ET CONNECTÉE

LEADER IN HYBRID SOLAR LIGHTING  
AND CONNECTED

SLS®

LA TECHNOLOGIE DU MODULE SOLAIRE PAR SOLAR LAMP SYSTEM

*The technology of the solar Module by Solar Lamp System*

Créé il y a 30 ans, l'éditeur français de meubles et d'éclairage outdoor MAIORI est le pionnier de la lampe solaire autonome. Sa place de leader tient à sa dimension internationale puisqu'il est présent dans 25 pays à travers le monde. L'éclairage autonome outdoor est une technologie innovante que MAIORI a continué à développer au sein de son équipe R&D pour donner naissance à une nouvelle génération de module solaire qui devient hybride et connecté Bluetooth. Rien d'étonnant à cela puisque l'entreprise continue à développer et à investir dans la recherche afin d'obtenir les modules les plus performants. Ceux-ci sont le résultat d'étude d'optimisation entre plusieurs paramètres : la taille du module, le temps de charge de la batterie, la puissance des LED.

Pour parvenir à cet équilibre à la fois technique et sophistiqué, le fabricant a pris soin de sélectionner les meilleurs conducteurs d'énergie sur le marché – des LED, un panneau solaire et une batterie – afin de les réunir dans un module breveté. Celui-ci est compact et s'intègre à la lampe ou à toute autre structure utilitaire ou décorative.

*Founded 30 years ago, French outdoor furniture and lighting manufacturer MAIORI is the pioneer of portable solar autonomous light design. Building on its global operations, the company is now an industry leader, with a presence in 25 countries worldwide. The outdoor solar lightings is an innovative technology that MAIORI has continued to develop to create a new generation of solar module which become now hybrid and Bluetooth connected. This new solar module remains even more efficient and keeps the right balance of efficiency between size, battery charging and lighting time/ power.*

*To achieve this balance between technology and sophistication, the manufacturer has handpicked the best energy conductors in the market - LEDs, a solar panel and a battery - and assembled them in a patented module. Highly compact, it can be integrated into a light or any other practical or decorative structure.*



À la fois technique et résistant, ce module est un générateur d'énergie. Sa conception garantit la fiabilité et la durabilité des luminaires solaires destinés à l'extérieur (toutes tailles et modèles confondus).

*Technically advanced and highly resistant, the module generates electricity. Its design guarantees the reliability and durability of its solar lights for outdoor use, whatever the size or model.*

#### CE MODULE SE COMPOSE :

- **D'un panneau solaire** monocristallin, dernière génération, à haute conversion lumière/ énergie (23%).
- **D'une batterie Lithium Ion** à haute résistance pour une utilisation optimale à -25°C et jusqu'à + 80°C.
- **De LED** : 3 W lumière chaude permet d'obtenir 300 lumens sur le grand module.

Tous les produits MAIORI sont testés et répondent aux normes internationales de solidité et de sécurité. De surcroît, les peintures poudre époxy sont à la fois non polluantes et résistantes aux intempéries.

#### THIS MODULE IS COMPOSED OF :

- A new generation high light-to-energy conversion (23%) monocrystalline **solar panel**.
- A high-resistance **lithium ion battery** for optimal use at -25°C to 80°C.
- **An LED** : 3 watt of warm light produces 300 Lumens for the large module.

*All MAIORI products are tested and comply with international safety and durability standards. The epoxy powder paints used on its products are non-polluting and weather resistant.*



# MAIORI

## LEADER DE LA LAMPE SOLAIRE HYBRIDE ET CONNECTÉE

LEADER IN HYBRID SOLAR LIGHTING AND CONNECTED

### L'ÉCLAIRAGE SOLAIRE : UNE RECHERCHE MONDIALE DEPUIS DEUX SIÈCLES

Le photovoltaïque est né, en 1839, grâce aux recherches du physicien Français Edmond Becquerel. En pionnier, il identifie « l'effet photoélectrique » (ainsi appelé à l'époque) sur des cellules exposées au soleil. Quatre vingts ans plus tard, en 1922, Albert Einstein remporte le prix Nobel pour ses études portant sur la technologie applicable à cet effet photoélectrique.

La LED est initiée en 1907 par Henri Joseph Round. Cet ingénieur Britannique est le premier à mettre en évidence le phénomène d'électroluminescence dont la LED est l'héritière. En 1927, le scientifique Russe, Oleg Losev, brevète avant tout le monde un iode électroluminescent. Plus de quarante ans après, l'ingénieur Américain, Nick Holonyak, attaché aux services de la General Electric, invente la première ampoule LED utilisable.

### AVANTAGES

Grâce à leur faible coût d'utilisation, les lampes solaires autonomes fabriquées par MAIORI se singularisent par leurs atouts multiples. La simplicité de leur fonctionnement n'a d'égale que leur grande mobilité. Pas de câblages, pas d'entretien, une sécurité fiable et une étanchéité garantie, ces lampes peuvent facilement s'installer dans les espaces intérieurs ou extérieurs totalement isolés : elles ne nécessitent aucun branchement électrique. Assurant un volume d'éclairage efficace, les lampes solaires de la gamme MAIORI s'abstiennent de toute pollution lumineuse, leur impact sur l'environnement étant quasi inexistant.

### SOLAR LIGHTING : TWO CENTURIES OF GLOBAL RESEARCH

*Photovoltaics were originally observed in 1839 by French physicist Edmond Becquerel. He was the first to identify what was then called the "photoelectric effect" on cells exposed to sunlight. Eighty years later, in 1922, Albert Einstein was awarded the Nobel Prize for his studies into technology applicable to the photoelectric effect.*

*British engineer Henry Joseph Round was the first to observe the phenomenon of light emission in 1907, which eventually lead to the development of the LED. In 1927, the Russian scientist Oleg Losev filed the earliest patent for a light-emitting diode. More than forty years later, American engineer Nick Holonyak, a General Electric employee, invented the original usable LED lightbulb.*

### ADVANTAGES

*Enjoying low operating costs, the autonomous solar lights produced by MAIORI offer a unique and wide range of advantages. As simple to use as they are easy to move, these lights are maintenance-free, wireless, reliably safe and guaranteed waterproof. Since they do not need to be plugged into the mains electricity supply, they are convenient for use in isolated indoor and outdoor areas. Producing an efficient amount of light, solar lights in the MAIORI range do not produce light pollution and have a near-zero impact on the environment.*



DESIGNED BY MD STUDIO

## LA LAMPE PARIS

### LE LAMPADAIRE SOLAIRE ICONIQUE

THE ICONIC SOLAR LAMP

Facile d'utilisation et modulable, choisissez de la suspendre en lanterne ou de la laisser en lampadaire. Sans fil, elle permet, où que vous soyez, un éclairage intérieur ou extérieur. Le système LED offre jusqu'à 300 lumens pour un maximum de 10h d'illumination en fonction de l'intensité lumineuse choisie. La Lampe Paris crée une ambiance douce et procure une lumière uniforme. **La lampe Paris** existe dans 22 combinaisons différentes. Choisissez parmi 2 couleurs de pieds, blanc ou noir et optez pour l'une de nos 11 couleurs d'abat-jour. Adoptez une lumière solaire unique.

*Easy going and adaptable **la Lampe Paris** is an outdoor solar lamp that works as both a hanging or standing lamp, and because it is wireless, you can virtually place it anywhere you are, indoors or outdoors. Delivering 300 lumens of light for up to 10 hours, depending on which of the settings you operate it, La Lampe Paris' LED bulb provides uniform warm global light to its surroundings. La Lampe Paris is available for customization through 22 colours arrangements. Select either black or white frame and throw in one of the striking colours shades to make it a very personal choice.*







Dotée du module solaire, hybride et connecté, la Lampe Paris est rechargeable au soleil ou via un dock USB et offre ensuite jusqu'à 10h d'autonomie. Elle est aussi connectée grâce à l'application mobile Maiori qui permet un contrôle à distance.

*Equipped with the solar module, hybrid and connected, La Lampe Padère is rechargeable in the sun or via a USB dock and then offers up to 10 hours of autonomy. It is also connected thanks to the Maiori mobile application which allows remote control. The aluminum base and foot are available in two colors, charcoal and white, its Batyline fabric shade in 11 colors.*

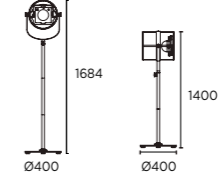

**LP8985**  
**La Lampe Paris**  
12,6kg







**LP9127**  
**La Lampe Tablette / Shelf**  
0.9kg





A1	F1	F2	F3	F9
A2	F10	F11	F12	F14
	F15	F17	F18	

A1	A2
----	----

# LA LAMPE PADERE

**LE TRADITIONNEL LAMPADAIRE DE VOS SALONS... EN VERSION SOLAIRE !**  
*THE TRADITIONAL LIVING ROOM FLOOR LAMP... SOLAR POWERED !*

**La Lampe Padère**, une déclinaison de l'icône lampe Paris. Un luminaire sur pied simple, brut et élégant qui diffuse parfaitement la lumière sur sa périphérie.

En option, la tablette circulaire de la Lampe Paris qui peut se positionner à deux hauteurs.

Dotée du module solaire, hybride et connecté, la Lampe Padère est rechargeable au soleil ou via un dock USB et offre ensuite jusqu'à 10h d'autonomie. Elle est aussi connectée grâce à l'application mobile Maiori qui permet un contrôle à distance. La base et le pied en aluminium se déclinent en deux couleurs, charbon et blanc, son abat-jour en tissu Batyline en 11 couleurs.

**La Lampe Padère**, a variation of the iconic Lampe Paris. A simple, raw and elegant free-standing luminaire that perfectly diffuses the light around its periphery.

As an option, the circular shelf of La Lampe Paris which can be positioned at two heights.

Equipped with the solar module, hybrid and connected, La Lampe Padère is rechargeable in the sun or via a USB dock and then offers up to 10 hours of autonomy. It is also connected thanks to the Maiori mobile application which allows remote control. The aluminum base and foot are available in two colors, charcoal and white, its Batyline fabric shade in 11 colors.



**LP6560**  
**La Lampe Padere**  
10,5kg

Ø550  
1700  
Ø395

☀️ 🔧 LED 🔋 📶

A1	F1	F2	F3	F9
A2	F10	F11	F12	F14
	F15	F17	F18	

**LP9127**  
**La Lampe Tablette / Shelf**  
0.9kg

Ø350

☀️ 🔧

A1
A2

DESIGNED BY MD STUDIO

# LA LAMPE PARABOLE

## LA LAMPE DE JARDIN PAR EXCELLENCE

THE TRUE SOLAR GARDEN LIGHT

Véritable lampe de jardin solaire, **La Lampe Parabole** se plante directement dans la terre grâce à son pied effilé. Fabriquée entièrement en aluminium laqué de couleur charbon ou blanc, son chapeau en demi-sphère est percé de quatre ouvertures permettant une diffusion de la lumière tout autour de cette lampe d'extérieur. Ajustable à deux hauteurs (320 cm and 500 cm), la Lampe Parabole est rechargeable au soleil ou via un dock USB et offre ensuite jusqu'à 10h d'autonomie. Elle est aussi connectée grâce à l'application mobile Maiori qui permet un contrôle à distance.



*A true solar garden lamp, **La Lampe Parabole** with its sharpened stake can be pitched directly to the soil. Made of powder-coated aluminum, its round half-sphered shape has four apertures, which provide an even spreading of solar powered light. Adjustable to two heights (320 cm and 500 cm). Equipped with the solar module, hybrid and connected, La Lampe Parabole can be recharged by the sun or via a USB dock and then offers up to 10 hours of autonomy. It is also connected thanks to the Maiori mobile application which allows remote control.*



LP9223

**La Lampe  
Parabole**

3kg

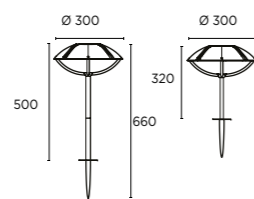

A1

A2



DESIGNED BY MD STUDIO

# LA LAMPE PASSAGE

UNE BALISE DESTINÉE À L'ÉCLAIRAGE DES CHEMINS D'ACCÈS ET JARDINS

LA LAMPE PASSAGE IS USED TO LIGHT ACCESS PATHS AND GARDENS

Elégante, cette lampe est fabriquée en aluminium laqué Epoxy. Elle peut se visser à un support ou bien juste être plantée dans le sol à l'aide de pointes à sa base.

Dotée du module solaire, hybride et connecté, **la Lampe Passage** est rechargeable au soleil ou via un dock USB et offre ensuite jusqu'à 10h d'autonomie. Elle est aussi connectée grâce à l'application mobile Maiori qui permet un contrôle à distance. Elle se décline en blanc et charbon.

*Elegant, this lamp is made of epoxy lacquered aluminium. It can be screwed to a support or just planted in the ground with spikes at its base.*

*Equipped with the solar module, hybrid and connected, **La Lampe Passage** can be recharged by the sun or via a USB dock and then offers up to 10 hours of autonomy. It is also connected thanks to the Maiori mobile application which allows remote control. It is available in white and charcoal.*



LP6523

**La Lampe Passage**

1,5kg

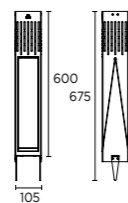

A1

A2

DESIGNED BY MD STUDIO

## LA LAMPE PARC

### LA VERSION SOLAIRE DE LA LAMPE TEMPÊTE *THE SOLAR VERSION OF THE HURRICANE LAMP*

Une icône. Conçue pour être la plus éblouissante de la collection **La Lampe Parc**, son éclairage fournit une lumière chaude et abondante, amplifiée par la pyramide réfléchissante située à la base. Entre ciel et terre. Au sol, la LP éclaire votre chemin, sur une table elle réchauffe l'atmosphère et grâce à son crochet vous pourrez la suspendre où vous le désirez... 3 hauteurs, 2 couleurs, c'est vous qui décidez. Variez les tailles selon l'utilisation, les grandes se marieront idéalement à vos grands espaces, alors que l'on s'orientera vers les petites pour une ambiance plus intimiste. Choisissez la sobriété du noir ou le luxe du blanc selon vos envies.

*Iconic. **La Lampe Parc** is a range of 3 outdoor solar garden lights ideal for path lighting. These solar powered garden lamps provide abundant and warm light in your garden. Place La Lampe Parc at floor level to light up your path, top of a table to provide cozy atmosphere, or use the U-hook provided to mount it on the wall. 3 heights, 2 colours. You decide. Get a tall size to don larger areas, or smaller size for mobility and intimate situations. Pick from sober black or luxury white depending on your style.*





**La Lampe Parc** est rechargeable au soleil ou via un dock USB et offre ensuite jusqu'à 10h d'autonomie. Elle est aussi connectée grâce à l'application mobile Maiori qui permet un contrôle à distance.

*Equipped with the solar module, hybrid and connected, **La Lampe Parc** can be recharged by the sun or via a USB dock and then offers up to 10 hours of autonomy. It is also connected thanks to the Maiori mobile application which allows remote control.*



LP9023-300

**La Lampe Parc S**

2,4kg

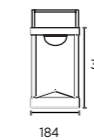

A1

A2



LP9023-400

**La Lampe Parc M**

2,5kg

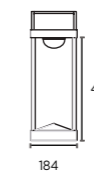

LP9023-500

**La Lampe Parc L**

2,6kg

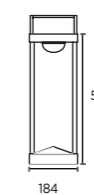



# LA LAMPE PETITE

## UNE VÉRITABLE LAMPE SPOT SOLAIRE

A GENUINE SOLAR SPOTLIGHT

**La Lampe Petite**, lampe de jardin solaire, elle brillera jusqu'à 10 heures après une journée de charge complète et vous accompagnera dans vos veillées les plus tardives. Conçue pour l'intérieur comme l'extérieur, La Lampe Petite habille les espaces où elle se trouve, posée ou suspendue. La lampe Petite existe dans 22 combinaisons différentes. Choisissez parmi 2 couleurs de pieds, blanc ou noir et optez pour l'une de nos 11 couleurs d'abat-jour. Adoptez une lumière solaire unique.

La Lampe Petite est rechargeable au soleil ou via un dock USB. Elle est aussi connectée grâce à l'application mobile Maiori qui permet un contrôle à distance.

*Industrious and energetic, La Lampe Petite's solar energy conversion ratio is yet to be matched. It shines for up to 10 hours with a full day under normal sun. You can be up all night, and then some. Suitable for indoors as well as outdoors use, La Lampe Petite dresses up the spaces where it is set or suspended with a mellow, warm natural light. Its Ultra-light structure makes it effortless carrying it around. La Lampe Petite is available for customization through 22 colours arrangements. Select either black or white frame and throw in one of the striking colours shades to make it a very personal choice.*

*Equipped with the solar module, hybrid and connected, La Lampe Petite can be recharged by the sun or via a USB dock. It is also connected thanks to the Maiori mobile application which allows remote control.*



LP9021  
**La Lampe Petite**  
2,0kg

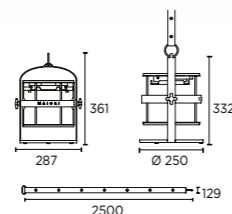

A1	F1	F2	F3	F9
A2	F10	F11	F12	F14
	F15	F17	F18	

DESIGNED BY MD STUDIO

# LA LAMPE PACHA

## LA VERSION SOLAIRE DE LA LANterne À BOUGIE

THE SOLAR POWERED VERSION OF THE CANDLE LIGHT LANTERN

Nomade, elle vous suivra à l'extérieur comme à l'intérieur. Grâce à son tissu tendu, cette lampe solaire décorative d'extérieur diffuse un halo de lumière douce pour créer une atmosphère chaude. Son cadre en aluminium laqué de couleur charbon ou blanc est habillé d'une chaussette en tissu enduit blanc cassé et imperméable. **La Lampe Pacha** est rechargeable au soleil ou via un dock USB et offre ensuite jusqu'à 10h d'autonomie. Elle est aussi connectée grâce à l'application mobile Maiori qui permet un contrôle à distance.

**La Lampe Pacha**, the solar powered version of a large candle lit lantern. A true nomad by nature it will follow you outside or inside the house. Due to its stretched fabric, it will provide a soft halo of light which will create a warm atmosphere. The frame is made of carbon or white powder coated aluminum and is dressed with a water-proof off-white coated fabric. Equipped with the solar module, hybrid and connected, La Lampe Pacha can be recharged by the sun or via a USB dock and then offers up to 10 hours of autonomy. It is also connected thanks to the Maiori mobile application which allows remote control.



LP9218

**La Lampe Pacha**

4,6kg

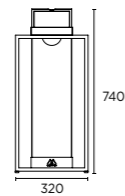

A1

A2

DESIGNED BY NORMAL STUDIO

## LA LAMPE COUTURE

**SOLAIRE ET DESIGN,  
LE LAMPION ANCESTRAL REVISITÉ**  
*THE CONTEMPORARY DESIGN VERSION  
OF THE ANCESTRAL LANTERN*

Le duo de designers signe pour la marque 3 luminaires de tailles différentes, tous conçus pour une utilisation extérieure.

Telle une lanterne céleste, **la Lampe Couture** évoque les lampions traditionnels asiatiques qui s'élèvent dans le ciel grâce à la chaleur d'une bougie. La Lampe Couture est composée d'un assemblage de pièces en textile diffusant qui augmente la capacité des leds pour révéler un volume de lumière sculptural.

*Normal Studio, have developed a collection of solar garden lamps that consists of three different sizes, including a transformative foot stand to hang them.*

*The lamps are, in the words of Normal Studio, "inspired by traditional Asian lanterns that gracefully float in the sky from the heat of a single candle" and include an innovative translucent material that conducts and enhances the degree of emitted light, maximizing the LED's capacity as well as emitting a soft warm glow.*











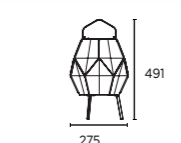

Entièrement conçue à partir de matériaux durables, elle résiste aux intempéries et est équipée des dernières technologies Maiori en matière d'énergie photovoltaïque et d'éclairage LED. Rechargée pendant la journée à l'énergie du soleil, cette lampe parfaitement autonome permet d'éclairer librement la terrasse ou le jardin d'une lumière douce et homogène.

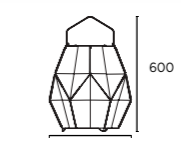
La Lampe Couture est rechargeable au soleil ou via un dock USB et offre ensuite jusqu'à 10h d'autonomie. Elle est aussi connectée grâce à l'application mobile Maiori qui permet un contrôle à distance.

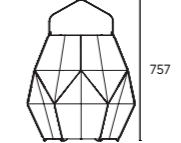
Entirely constructed from sustainable materials, these lamps also incorporate Maiori's trademark LED lighting and photovoltaic energy technology. Every **Couture Lamp** has a handle, making them versatile and providing options for lighting up a table, hanging from a tree, lighting the area around the swimming pool or simply left on the stand.

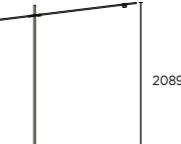
Equipped with the solar module, hybrid and connected, La Lampe Couture can be recharged by the sun or via a USB dock and then offers up to 10 hours of autonomy. It is also connected thanks to the Maiori mobile application which allows remote control.

	<p>LP9731 <b>La Lampe Couture S</b> 1,2kg</p>		 <p>A2   F22</p>
	<p>LP9722 <b>La Lampe Couture M</b> 2,2kg</p>		
	<p>LP9732 <b>La Lampe Couture L</b> 3,0kg</p>		
	<p>LP9721 <b>La Lampe Couture Stand</b> 22,2kg</p>		 <p>A2</p>

DESIGNED BY MD STUDIO

# LA LAMPE PAILLOTE

## EXOTIQUE AVEC SA FINITION NATURELLE

EXOTIC WITH A NATURAL FINISH

**La Lampe Paillote** est en forme de sphère. Composée d'une structure en tube d'aluminium, elle est ensuite recouverte d'un tissage ouvert de fibre PE finition naturelle. Elle apporte volupté et chaleur aux espaces extérieurs.

Dotée du module solaire, hybride et connecté, la Lampe Paillote est rechargeable au soleil ou via un dock USB et offre ensuite jusqu'à 10h d'autonomie. Elle est aussi connectée grâce à l'application mobile Maiori qui permet un contrôle à distance.

La Paillote est disponible en 3 tailles à poser ou suspendre.

**La Lampe Paillote** is shaped like a sphere. Composed of an aluminium tube structure, it is then covered with an open weave of natural finish PE fibre. It brings voluptuousness and warmth to outdoor spaces.

Equipped with the solar module, hybrid and connected, La Lampe Paillote can be recharged by the sun or via a USB dock and then offers up to 10 hours of autonomy. It is also connected thanks to the Maiori mobile application which allows remote control.

La Lampe Paillote is available in 3 sizes for hanging or standing.



LP6578

**La Lampe Paillote  
Sphere S**

2,0kg

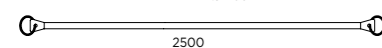
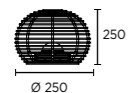

LP6579

**La Lampe Paillote  
Sphere M**

2,5kg

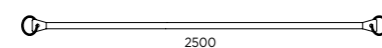
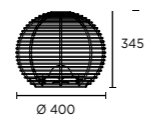

LP6580

**La Lampe Paillote  
Sphere L**

3,0kg

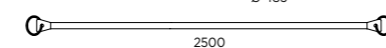
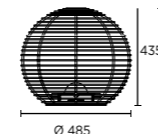

DESIGNED BY MD STUDIO

# LA LAMPE POSE 01

## PETITE MAIS INTELLIGENTE

SMALL & CLEVER TABLE SOLAR LAMP

Une icône discrète. Légère et étanche La lampe extérieur solaire Pose est polyvalente par sa conception. Sa sobriété, simplicité et son système sans fil, lui permettent de s'adapter à tous les espaces, intérieurs ou extérieurs. Dotée de notre module solaire, hybride et connecté, **la Lampe Pose 01** est rechargeable au soleil ou via un dock USB et offre ensuite jusqu'à 10h d'autonomie. Elle est aussi connectée grâce à l'application mobile Maiori qui permet un contrôle à distance. La puissance de 100 lumens garantit une lumière chaude. Malgré sa taille, La Lampe Pose éblouit de grandeur.

*La Lampe Pose is a range of solar powered table lamps featuring a 10 cm high-conversion solar module, this wireless lamps work for up to 5 hours in a full battery, providing 100 Lumens of warm and focused light. Lightweight, weatherproofed... **La Lampe Pose 01** is versatile by design. The understated simplicity of its design, plus its wireless system makes it perfect for any space, indoor or outdoor.*

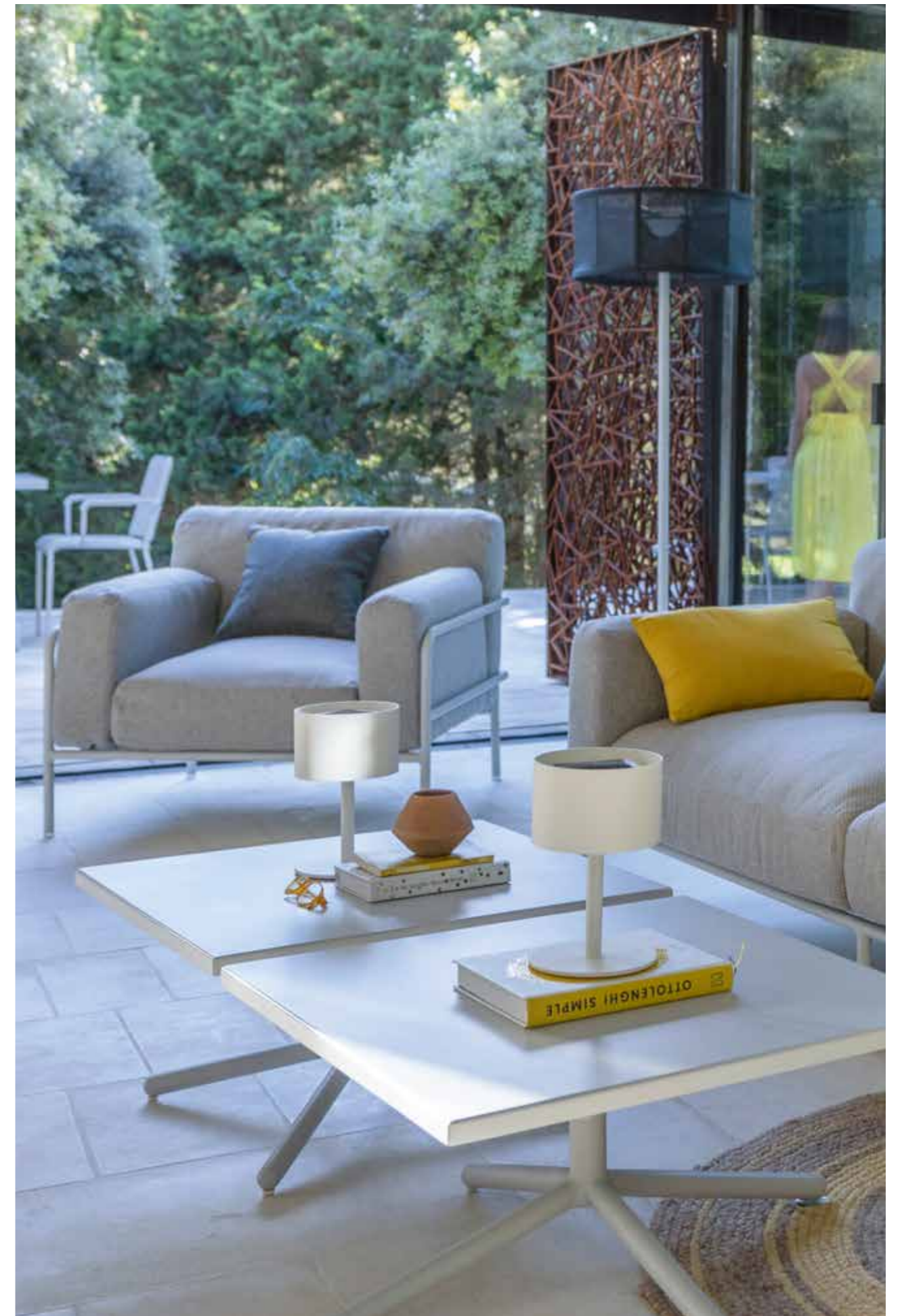

LP9137

**La Lampe Pose 01**

1kg

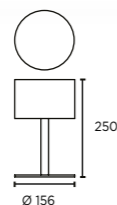

A1 A2 A3 A7 A14

DESIGNED BY MD STUDIO

## LA LAMPE POSE 02

### PETITE LAMPE SOLAIRE PRATIQUE POUR ILLUMINER VOTRE TABLE

HANDY SOLAR LAMP TO ILLUMINATE YOUR TABLE

Une icône discrète. Légère et étanche **La lampe Pose 02** est polyvalente par sa conception. Sa sobriété, simplicité et son système sans fil, lui permettent de s'adapter à tous les espaces, intérieurs ou extérieurs. Dotée de notre module solaire, hybride et connecté, la Lampe Pose 02 est rechargeable au soleil ou via un dock USB et offre ensuite jusqu'à 10h d'autonomie. Elle est aussi connectée grâce à l'application mobile Maiori qui permet un contrôle à distance. La puissance de 100 lumens garantit une lumière chaude. Malgré sa taille, La Lampe Pose éblouit de grandeur.



*La Lampe Pose 02 is a range of solar powered table lamps featuring a 10 cm high-conversion solar module, this wireless lamps work for up to 5 hours in a full battery, providing 100 Lumens of warm and focused light. Lightweight, weather-proofed... La Lampe Pose is versatile by design. The understated simplicity of its design, plus its wireless system makes it perfect for any space, indoor or outdoor.*



LP9136

**La Lampe Pose 02**

0.9kg

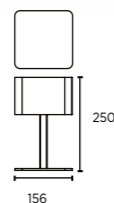

A1 A2 A3 A7 A14

DESIGNED BY MD STUDIO

# LA LAMPE POSE MINI

## UNE LAMPE DE TABLE DESIGN ET DISCRÈTE

A DESIGN AND DISCREET TABLE LAMP

Elle éclairera élégamment les espaces extérieurs comme intérieurs. Dotée du module solaire, hybride et connecté, **La Lampe Pose Mini** est rechargeable au soleil ou via un dock USB et offre ensuite jusqu'à 10h d'autonomie. Elle est aussi connectée grâce à l'application mobile Maiori qui permet un contrôle à distance. Faite d'aluminium et de tissu Batyline décliné en 5 couleurs, elle s'accordera parfaitement avec le reste de notre collection : Les lampes Paris, Petite, Padère.



*It will elegantly illuminate both outdoor and indoor spaces. Equipped with the solar, hybrid and connected module, **La Lampe Pose Mini** is rechargeable in the sun or via a USB dock and then offers up to 10 hours of autonomy. It is also connected thanks to the Maiori mobile application which allows remote control. Made of aluminum and Batyline fabric available in 5 colors, it will go perfectly with the rest of our collection: Paris, Petite, Padère lamps*

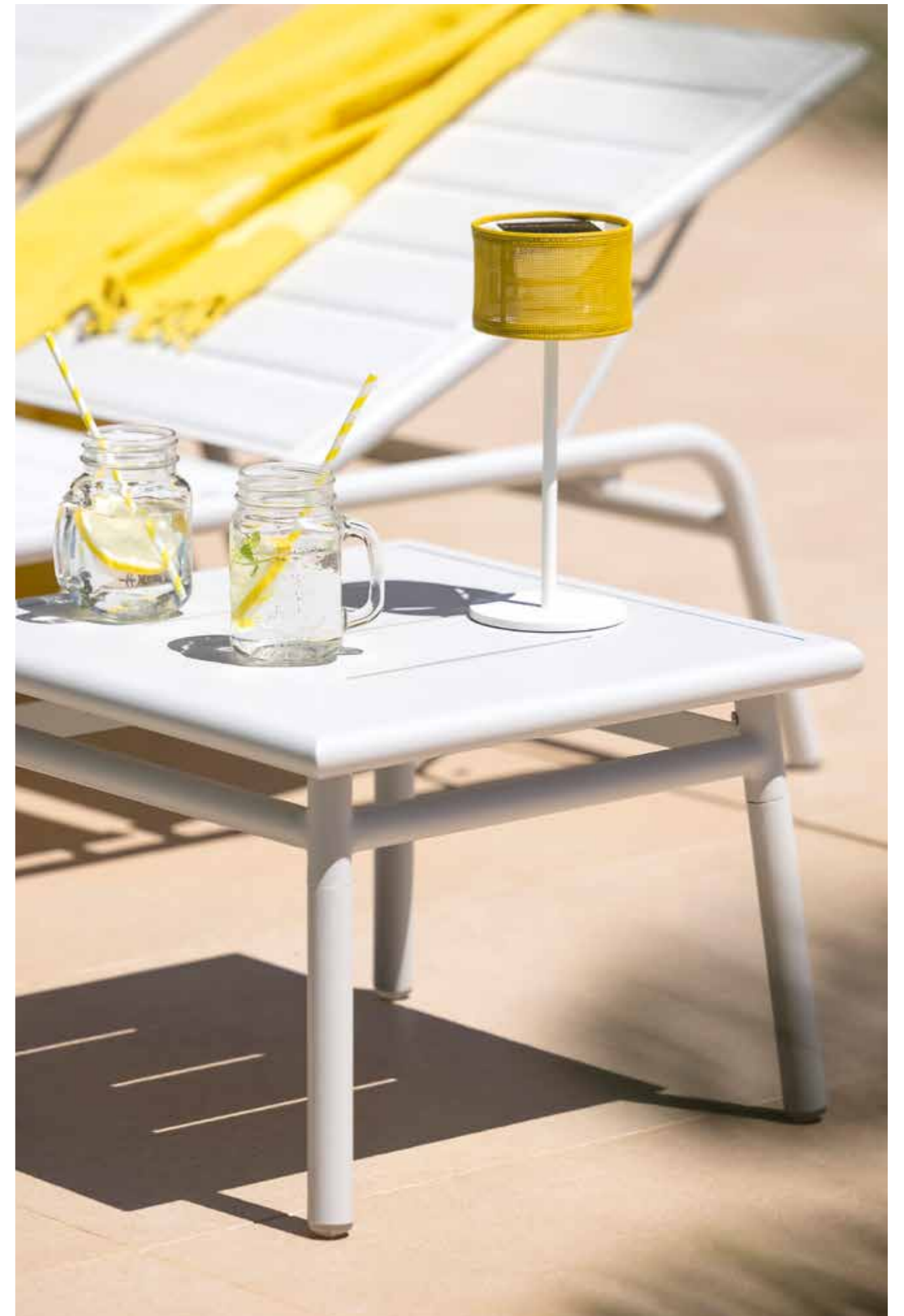

LP5505

**La Lampe Pose MINI**

0,3kg

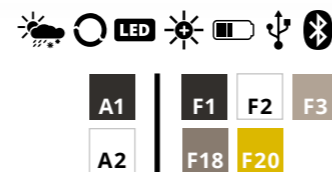
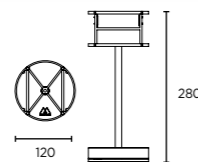



DESIGNED BY MD STUDIO

# LA LAMPE POSE 04

## UN PHOTOPHORE DE TABLE

A CANDLE HOLDER OF TABLE

Petite et chaleureuse, ses perforations permettent la diffusion d'une lumière chaude et délicate. Le charme d'un éclairage naturel à la bougie.

Sa petite taille s'adaptera à toutes les réunions de convivialités. **La Lampe Pose 04** est rechargeable au soleil ou via un dock USB et offre ensuite jusqu'à 10h d'autonomie. Elle est aussi connectée grâce à l'application mobile Maiori qui permet un contrôle à distance. Faite d'aluminium, elle se décline en 5 couleurs.

*Small and warm, its perforations allow the diffusion of a warm and delicate light. The charm of natural candlelight.*

*Its small size will adapt to all convivial meetings. **The Pose 04 lamp** can be recharged by the sun or via a USB dock and then offers up to 10 hours of autonomy. It is also connected via the Maiori mobile application which allows remote control. Made of aluminium, it is available in 5 colours.*

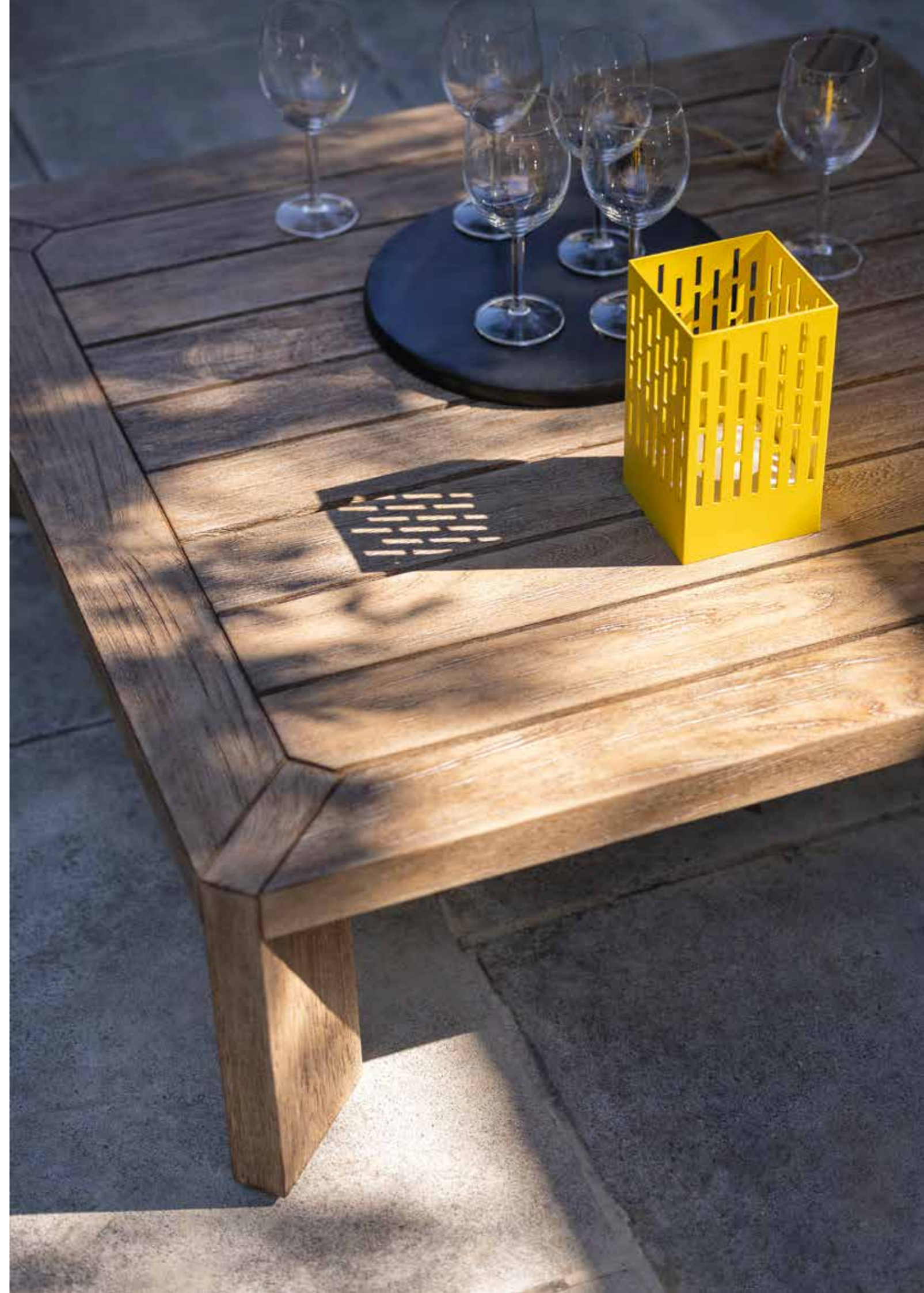

LP9225

**La Lampe Pose 04**

0,5kg

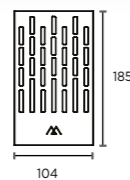

DESIGNED BY MD STUDIO

## LA LAMPE POP UP

**LA PLUS PETITE DE LA COLLECTION INSPIRÉE DE L'ART JAPONAIS KIRIGAMI**  
*THE SMALLEST OF THE COLLECTION INSPIRED BY THE JAPANESE ART KIRIGAMI.*

La plus petite de la gamme de Lampe solaire MAIORI, **La Lampe PopUp** est grande par sa conception et sa technologie: un aluminium coupé au laser, puis formé.

La Lampe MAIORI PopUp a été créée pour surgir n'importe où et à tout moment : sur vos tables, dans le jardin, ou encore sur votre terrasse. Très compacte elle se glissera facilement dans un sac, et offrira de la lumière où que vous soyez. Son design et sa luminosité surprendra et attirera l'attention de tous.

L'abat-jour en aluminium laqué a été dessiné et s'inspire de l'art Japonais appelé Kirigami qui consiste à découper du papier et lui donner différentes formes souvent articulées. Beaucoup l'utilise pour réaliser des cartes « Pop Up » avec des motifs qui se mettent en volume lors de son ouverture. Cet art devenu très populaire dans beaucoup de pays est toujours associé à l'annonce d'un événement heureux.

La Lampe Pop Up est rechargeable au soleil ou via un dock USB et offre ensuite jusqu'à 10h d'autonomie. Elle est aussi connectée grâce à l'application mobile Maiori qui permet un contrôle à distance.

The smallest solar lamp in MAIORI's range, **the PopUp lamp** is big on design and technology, and made from laser-cut, shaped aluminium.

*The MAIORI PopUp lamp is designed to "pop up" anywhere, at any time - on a table, in the garden, or even on a terrace. Extremely compact, it fits easily into a bag to provide light wherever you are. Its eye-opening design and luminosity will not go unnoticed.*

*The design of the lacquered aluminium lampshade was inspired by a Japanese art form - Kirigami - which consists in cutting paper and giving it different shapes, often with moveable joints. It is widely used to make "Pop Up" cards that create relief patterns when opened. This art form, now very popular in many countries, is still associated with the announcement of a happy event.*

*Equipped with the solar module, hybrid and connected, La Lampe PopUp can be recharged by the sun or via a USB dock and then offers up to 10 hours of autonomy. It is also connected thanks to the Maiori mobile application which allows remote control.*

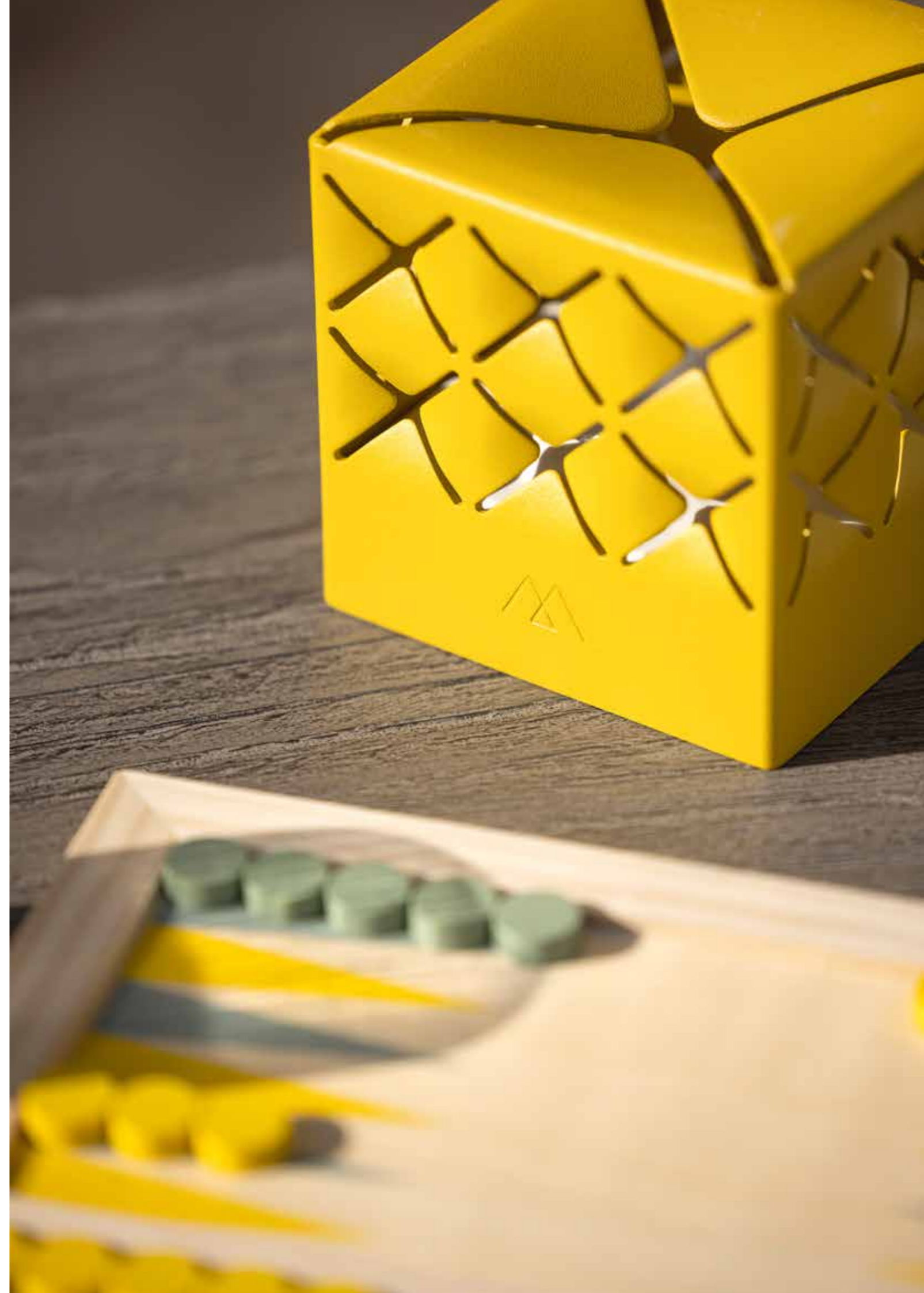

LP6505

**La Lampe PopUp**

0,5kg

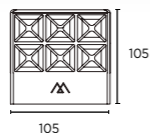

DESIGNED BY MD STUDIO

## LA LAMPE GUIRLANDE

### UNE LIANE LUMINEUSE

THE GARLAND, A LUMINOUS CREEPER

Torsadée, notre **guirlande** lumineuse s'entremêle autour d'une branche, ou se suspend au dessus d'une table, pour apporter une lumière douce et chaleureuse à vos soirées.

Telle une liane, la guirlande s'adapte par ces courbes et son revêtement en batyline lui confère grâce et volupté.

Disponible en 3 mètres, la guirlande se connecte au powerbank avec une autonomie de 10h.

*Twisted, our lighted **garland** can be entwined around a branch or hung over a table to bring a soft and warm light to your evenings.*

*Like a creeper, the garland adapts itself by its curves and its batyline covering gives it grace and voluptuousness.*

*Available in 3 meters, the garland connects to the powerbank for an autonomy of 10h.*



LP5513

La Guirlande

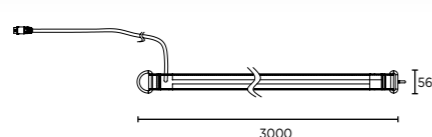

## LES PORTE-LAMPES

### MAIORI COMPLÈTE SA GAMME AVEC UNE COLLECTION DE PORTE-LAMPES DE JARDIN FAÇON SCULPTURE ET DE STYLE 'FER FORGÉ' CHIC ET LUDIQUE

MAIORI COMPLETES ITS RANGE WITH A COLLECTION OF GARDEN LAMP HOLDERS IN THE FORM OF SCULPTURES AND IN A CHIC AND PLAYFUL 'WROUGHT IRON' STYLE.

En forme d'Escargot, Hibou et Chat, ils permettront d'accessoiriser et d'accrocher les modèles de la série : Les lampes POSE & POPUP.

Ils s'implantent facilement dans tout type de sols grâce à des pointes à leurs bases et allient l'utile en vous éclairant la nuit, à l'agréable en décorant votre jardin.

Uniquement proposés en couleur Charbon.

*In the shape of a Snail, Owl and Cat, they can be used to accessorise and hang the models in the range of : POSE & POPUP lamps.*

*They can be easily installed in any type of soil thanks to the spikes at their bases and combine the usefulness of lighting up your garden at night, with the pleasure of decorating it.*

*Only available in Charcoal colour.*



LP6570

**L'escargot**

2,6kg

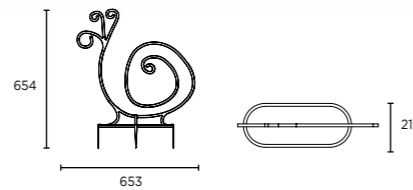

A1



LP6595

**Le chat**

2,6kg

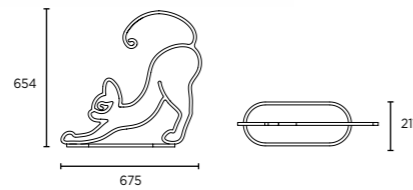

LP6589

**Le hibou**

2,6kg

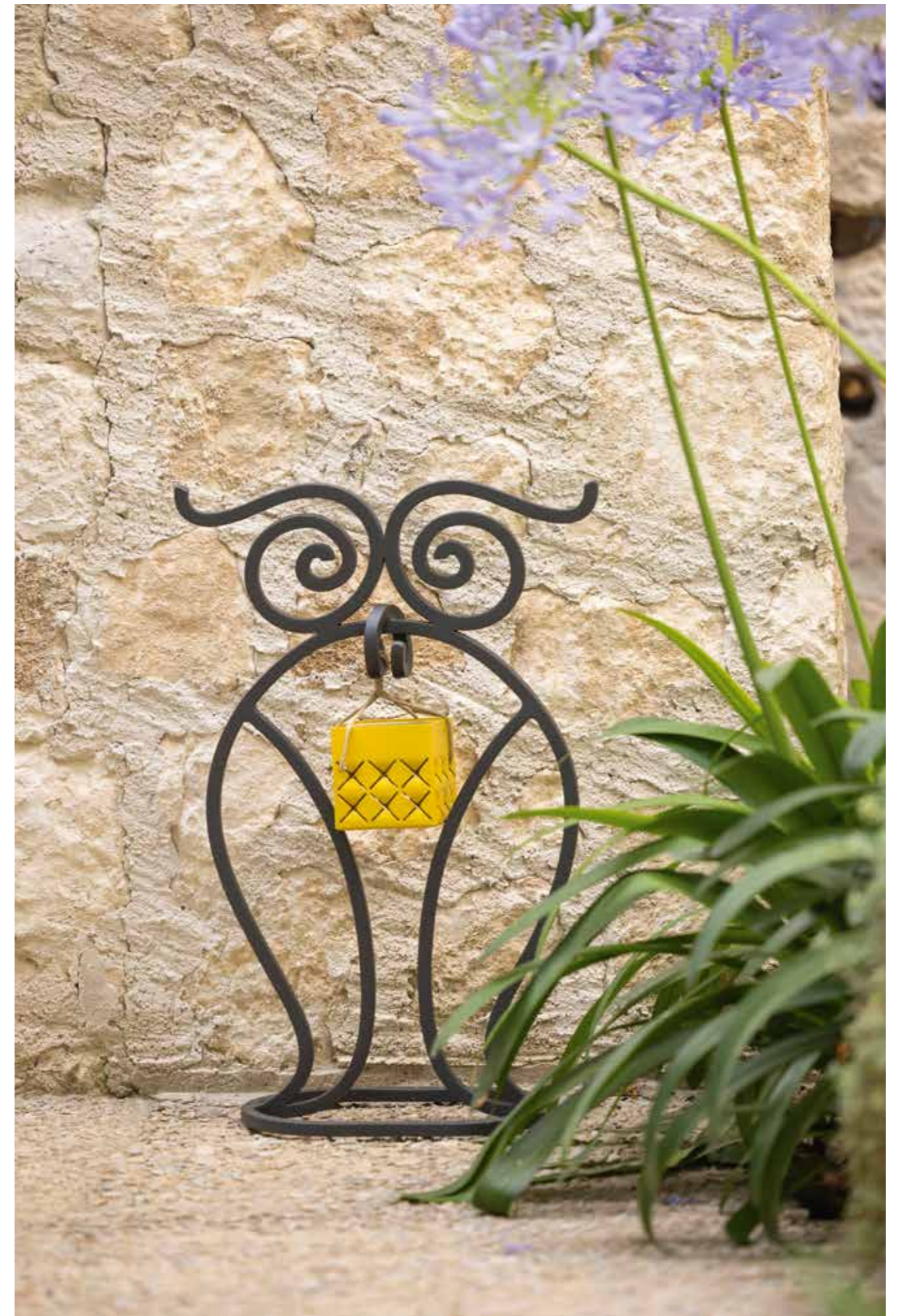
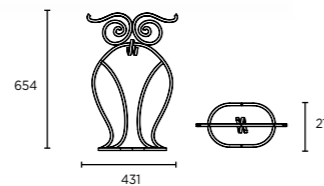

## LA LAMPE

# ACCESSOIRES

ACCESSORIES & SPARE PARTS

### LA TABLETTE / SHELF



La tablette transforme les Lampes Paris et Padere en un produit multi-fonctionnel. Elle s'adapte parfaitement et les convertit en une petite table auxiliaire qui s'harmonise parfaitement à côté de vos assises ou seule. Conçue en aluminium avec une finition en peinture époxy, elle permet d'y placer n'importe quel objet. Robuste, elle résiste aux intempéries.

*The Paris Tray converts La Lampe Paris and Padere into a multi-functional product. It fits tightly on them and turns it into an auxiliary table which sits perfectly next to your seating or as standalone. Made of aluminium with epoxy paint finished, which allow glassware or any object securely placed on top. It is sturdy and weather resistant.*

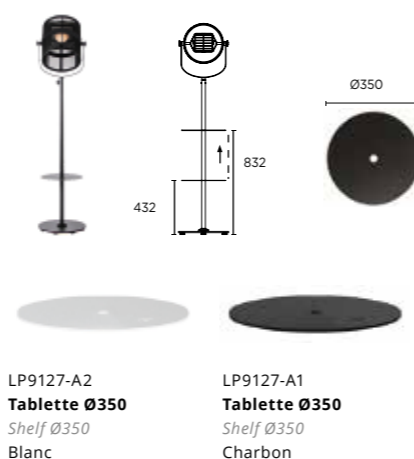

LP9127-A2  
Tablette Ø350  
Shelf Ø350  
Blanc

LP9127-A1  
Tablette Ø350  
Shelf Ø350  
Charbon

### LA SANGLE / BELT



La sangle transforme facilement La Lampe Petite en une lanterne élégante. Avec sa longueur totale de 250cm, la hauteur peut être ajustée selon vos besoins. Le système de crochet permet d'installer la lampe sans effort.

*Petite Belt easily transforms La Lampe Petite into a stylish lantern. With the total length of 250cm, the height could be adjusted as you need. The hook system allows you to secure the position of the lamp effortlessly.*



LP6519-A2  
Sangle Petite  
Petite Belt  
Blanc

LP6519-A1  
Sangle Petite  
Petite Belt  
Charbon

### PLATEAU DE CHARGEMENT USB 8 MODULES / CHARGING TRAY USB FOR 8 MODULES

Le plateau de chargement solaire permet de recharger efficacement plusieurs modules S/B en même temps sans avoir à manipuler les lampes. Il est spécialement conçu pour l'extérieur, avec un cadre en aluminium peint, il résiste aux intempéries.

*The Solar Charging Tray allows you to efficiently recharge multiple modules S/B at the same time instead of moving your lamps around. It is specially designed for outdoors, made of weather resistant oven cured painted aluminium frame.*



Nos plateaux de chargement sont empilables /  
Our charging tray are stackable

LP6509  
Le Plateau de  
chargement  
Peut contenir jusqu'à 8  
modules  
Charging Tray /  
Can charge up to 8 Modules

LP6509-WHEEL  
Le Plateau de  
chargement  
4 Roues amovibles pour  
plateau de chargement  
4 removable wheels for  
charging tray

### LE MODULE SOLAIRE HYBRIDE / SOLAR HYBRID MODULE



Le module Hybride recueille la lumière du soleil et produit de l'électricité pendant la journée. En cas de mauvais temps, le module se recharge également à l'aide d'un dock USB. L'énergie est ensuite stockée dans la batterie et restituée la nuit. Il délivre de 75 à 300 lumens et donne jusqu'à 10h d'éclairage. Il offre une lumière uniforme et chaleureuse.

Celui-ci est équipé et connecté à l'aide d'un émetteur Bluetooth qui permet grâce à une application, un fonctionnement et une programmation à distance.

*The Hybrid Module collects the light from the sun and produces electricity during the day. In case of bad weather, the module can charge through USB dock. The energy is then stored in the battery and restored at night. They deliver from 75 - 300 lumens of light for up to 10 hours at night, which provide uniform warm global light to the surrounding.*

*They can be also connected to the MAIORI app, which enabled remote operation and programming using a Bluetooth transmitter.*



SOLAR HYBRID MODULE B  
3 intensités / 3 intensities  
Jusqu'à 10 h d'autonomie /  
Up to 10 hours Autonomy  
Chargement en 5 h /  
5 hours Charging  
1000 Cycles

SOLAR HYBRID MODULE S  
2 intensités / 2 intensities  
Jusqu'à 10 h d'autonomie /  
Up to 10 hours Autonomy  
Chargement en 5 h /  
5 hours Charging  
1000 Cycles

SOLAR HYBRID MODULE MINI  
2 intensités / 2 intensities  
Jusqu'à 10 h d'autonomie /  
Up to 10 hours Autonomy  
Chargement en 5 h /  
5 hours Charging  
1000 Cycles



COLLECTION  
**LE MOBILIER**



DESIGNED BY NORMAL STUDIO

# AT800

## LE DESIGN, TOUT SIMPLEMENT

A STATEMENT  
IN DESIGN SIMPLICITY

La collection **AT800** associe, dans sa version pliante, deux matériaux parmi les plus réputés en mobilier d'extérieur. La souplesse de l'aluminium et la dureté du teck se rencontrent, dans le plus grand respect des matériaux, mais aussi dans le souci de la fonctionnalité et du style. L'emploi d'aluminium embouti pour l'assise incarne la prouesse d'un design fonctionnel, fruit d'une esthétique nostalgique et d'une production industrielle.

**AT800 Series** combines in its foldable version two of the most celebrated materials in outdoor furniture. A soft metal and a hard wood, Aluminium and Teak, are used efficiently and respectfully throughout with function and aesthetics in mind. The use of stamped aluminium for the seating, speaks volumes about functional design, a blend of nostalgia aesthetics and industrial production that is hard to come by.





- ① LA LAMPE PACHA - White (A2) - Lux (F22)
- ② LA LAMPE POSE 01 - Moutarde (A7)
- ③ LA LAMPE PADERE - White (A2) - Lemon (F10)
- ④ GREENS DUO - White (A2)





Grâce à leur système modulaire (une pièce angulaire en aluminium injecté qui s'emboîte et relie les traverses de la table aux pieds), les tables offrent de nombreuses configurations possibles et peuvent se ranger à plat, pour un transport facilité. Le plateau en métal perforé laisse passer la pluie et la lumière, tout en réduisant également le poids de la table et en limitant au maximum l'ombre projetée en dessous. Une table aérée et qui sait faire le vide.

*The modular system employed on the tables, based on a injected aluminium corner-piece that slots over and links the table crossbars with the legs, allows not only multi-configuration, but also for the whole thing to fold into a flat cardboard box, making transportation efficient. The perforated sheet metal tabletop lets rain and light through, reducing the table's weight and creating a minimum of shadow underneath. In fact the table has more void than matter.*

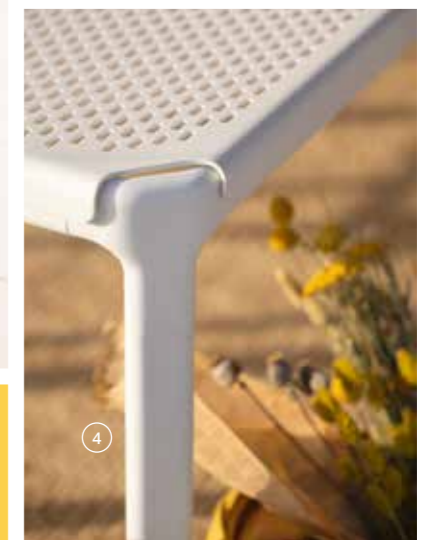

- ① AT800 - FOLDABLE ARMCHAIR - White (A2) - Teck (T1)
- ② AT800 - TABLE - White (A2)
- ③ AT800 - ARMCHAIR - White (A2)
- ④ AT800 - ALUMINIUM TABLE - White (A2)



AT9707  
**AT800 Armchair**  
 6,1kg

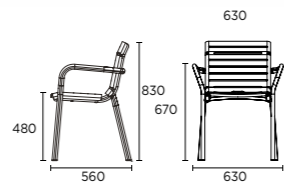

AT8896  
**AT800 Aluminium Table 80x80**  
 15,7kg

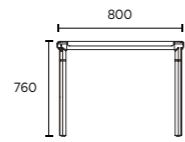

AT8883  
**AT800 Aluminium Table 100x100**  
 18kg

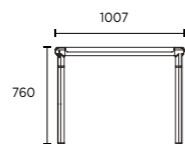

AT8884  
**AT800 Aluminium Table 100x200**  
 31,5kg

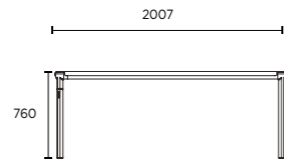

AT8899  
**AT800 Foldable Chair**  
 7,2kg

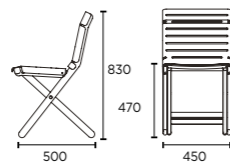

AT8889  
**AT800 Foldable Armchair**  
 7,9kg

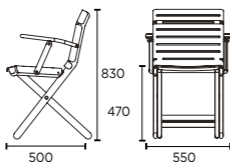

AT8896  
**AT800 Table 80x80**  
 15,7kg

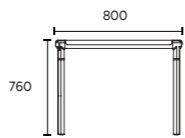

AT8883  
**AT800 Table 100x100**  
 18kg

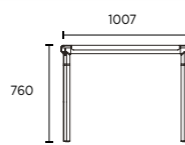

AT8884  
**AT800 Table 100x200**  
 31,5kg

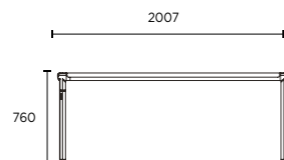

DESIGNED BY MD STUDIO

# STIPA

## L'ÉMOTION SANS COMPROMIS

WHOLESOME EMOTION

Avec son design emblématique, **Stipa** ré-interprète la tradition méditerranéenne grâce au talent des maîtres du design industriel de MAIORI Design. Découvrez des objets séduisants et authentiques, fabriqués à partir de matériaux extérieurs bien pensés.

La fibre synthétique employée dans la collection Stipa est un composant recyclable similaire à la paille, au toucher doux et agréable. Cette fibre est résistante aux intempéries, aux rayons UV, aux bactéries ainsi qu'à la pollution environnementale et chimique. Ce composant exclusif est extrudé et torsadé, pour ensuite être tissé dans un cadre aluminium T6 haute performance, permettant d'obtenir un produit durable.

*Stipa compiles the wholesome Mediterranean flavour of an enduring icon as reinterpreted by the industrial design maestros at MAIORI Design. A series of authentic desire objects built with smart outdoor materials.*

*The synthetic fiber used in Stipa is a recyclable straw-like composite with a warm and soft hand feel that is resistant to weather, UV rays, bacteria and environmental as well as chemical pollution. This exclusive composite is extruded and twisted to later be woven into a high performance Aluminum T6 frame to complete a durable and sustainable proposition.*





- ① STIPA TABLE 100x100 - White (A2)
- ② STIPA BENCH - White (A2) - White Wash (WS5)
- ③ STIPA STOOL - White (A2) - Naturel (WS3)
- ④ STIPA BAR CHAIR - White (A2) - Naturel (WS3)
- ⑤ STIPA BAR CHAIR - Charbon (A1) - Naturel (WS3)
- ⑥ HUGGY BAR TABLE - Charbon (A1) - Vintage Grey Teck (T3)





- ① STIPA CHAIR - White (A2) - White Wash (WS5)
- ② STIPA TABLE 100x300 - White (A2)
- ③ STIPA ARMCHAIR - White (A2) - White Wash (WS5)
- ④ STIPA LOW CHAIR - White (A2) - Naturel (WS3)
- ⑤ STIPA ARMCHAIR - White (A2) - White Wash (WS5)





ST9827  
**Stipa Chair**  
5,2kg

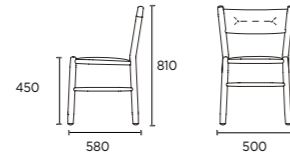

- A1
- A2
- A25
- WS3
- WS5



ST9828  
**Stipa Armchair**  
5,7kg

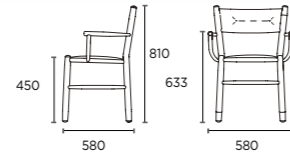

ST9092  
**Stipa Bar Chair**  
5,8kg

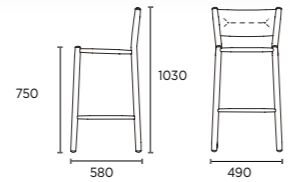

ST9868  
**Stipa Bar Armchair**  
8,9kg



ST9878  
**Stipa Stool H75**  
5,6kg



ST8571  
**Stipa Stool H45**  
2,9kg

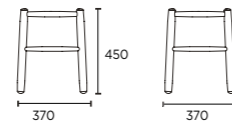

ST5450  
**Stipa Low Chair**  
29kg

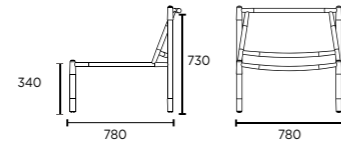

ST9082  
**Stipa Bench**  
6,5kg

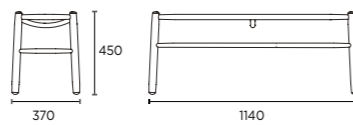

ST9086  
**Stipa Banquette**  
10,5kg

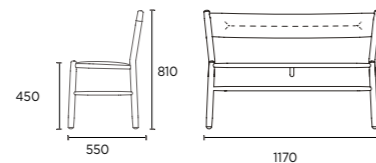

① STIPA ARMCHAIR - White (A2) - Naturel (WS3)  
② STIPA CHAIR - White (A2) - White Wash (WS5)



ST5451  
**Stipa Ottoman**  
6,4kg

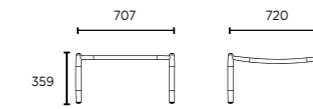

- A1
- A2
- A25
- WS3
- WS5



ST9838  
**Stipa Side Table 50x50**  
5,6kg

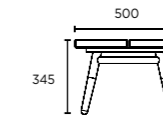

- A1
- A2
- A25



ST9393  
**Stipa Aluminium Table 100x100**  
17,3kg

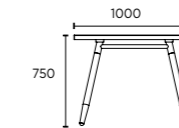

ST9318  
**Stipa Aluminium Table 100x200**  
30kg

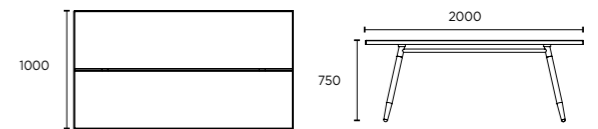

ST9395  
**Stipa Aluminium Table 100x300**  
39,8kg

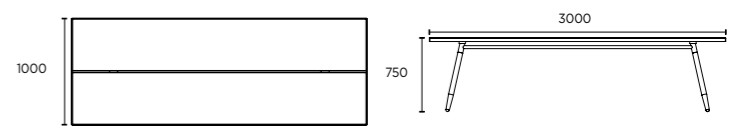

DESIGNED BY ANTOINE LESUR

# HUGGY

## UNE SENSUALITÉ BIEN PENSÉE

BRILLIANTLY CRAFTED SENSUALITY

Chaque pièce **Huggy** incarne un concept à la fois affirmé et tout en retenue. Le fauteuil emblématique, mais aussi le tabouret aux lignes légères, le portemanteau iconique... Huggy revisite le mobilier de bistro, fort d'une esthétique unique et d'une légèreté jamais vue.

L'absence totale d'angles vifs, les perspectives nonchalantes et la conception robuste sont autant d'exemples d'ingénierie au service de l'originalité. Prenez une construction en aluminium T6 légère et robuste, ajoutez-y un revêtement thermolaqué caractéristique et vous obtenez une pièce haute performance quels que soient la pièce et l'environnement, en intérieur comme en extérieur.

La table Huggy accueille confortablement 4 personnes assises sur des fauteuils ou des tabourets. Plus grande pièce de la collection, cette table est un objet ludique et accrocheur, conçu et construit avec talent.

Chaque pièce Huggy suit une ligne conductrice, basée sur une courbe continue qui trace l'objet et lui confère une fonction unique dans la collection.

*Every **Huggy** piece is a standalone statement full of character and restraint. The emblematic armchair, the playful stools, the charismatic hanger ... Huggy revisits bistro furniture to redefine it with a unique aesthetic and unseen playfulness.*

*Containing exactly zero sharp angles, its nonchalant outlook and sturdy design are an example of brilliant engineering at the service of originality. A body of aluminum T6 means every piece is ultra light yet heavy-duty, add a layer of trademark powder coating and you have a high performance promise from any piece, on any location, in or outdoors.*

*The Huggy dining table is designed to accommodate 4 people easily, sided by armchairs or stools. The biggest of all the range, it is a fun and eye catchy object, designed and built brilliantly.*

*Every Huggy piece is designed as a continuum of each other. Based on a continued curve that draws the object and gives it its unique function within the range.*





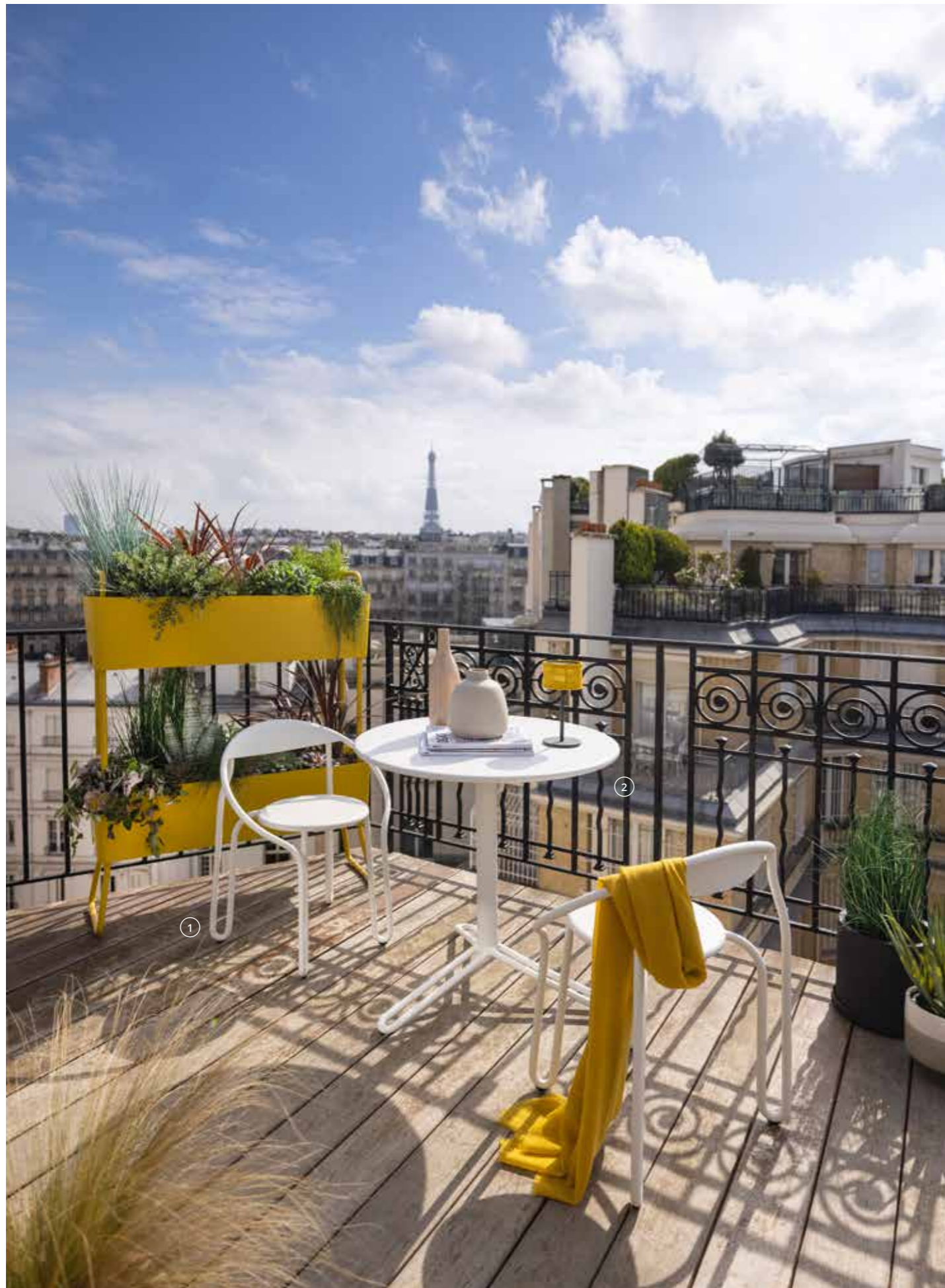

- ① HUGGY BISTRO CHAIR - White (A2)
- ② HUGGY BISTRO TABLE Ø75 - White (A2)
- ③ HUGGY BISTRO CHAIR - White (A2) - White Pearl (WF29)
- ④ HUGGY BAR STOOL - Charbon (A1) - Vintage Grey (T3)
- ⑤ HUGGY BAR TABLE - Charbon (A1) - Vintage Grey (T3)





HU9988  
**Huggy Armchair**  
4,3kg

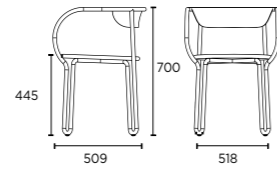

Structure / Frame

A1 A2 A7 A25

Assises / Seats

WF28 WF29 WF30 WF31



HU9933  
**Huggy Bistro Chair**  
3kg

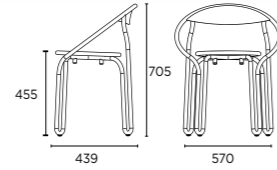

HU9935  
**Huggy Bistro Bench**  
7,2kg

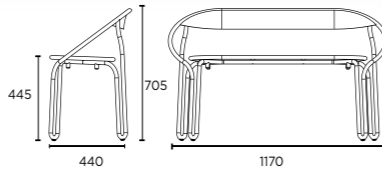

HU9927  
**Huggy Stool H45**  
2,3kg

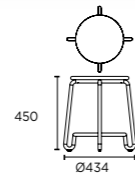

HU9911  
**Huggy High Dining Stool H65**  
3kg

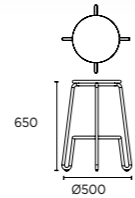

HU9905  
**Huggy Bar Stool H75**  
3,2kg

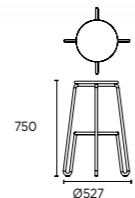

HU9913  
**Huggy Bar Table**  
6kg

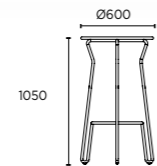

Structure / Frame

A1 A2 A7 A25

Plateau / Top

T1 T2 T3



HU9936  
**Huggy Bistro Table Ø60**  
11,5kg

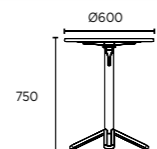

Structure / Frame

A1 A2 A7 A25

Plateau / Top

T1 T2 T3



HU9982  
**Huggy Bistro Table Ø75**  
15,3kg

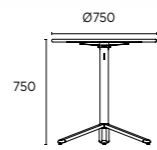

HU9902  
**Huggy Coat Hanger**  
5,5kg



Structure / Frame

A1 A2 A7 A25



HU9926  
**Huggy Armchair Seat Cushion**  
0,22kg

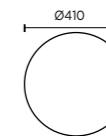

Structure / Frame

C4 C5 C8



HU9925  
**Huggy Stool Seat Cushion**  
0,13kg

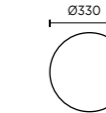

DESIGNED BY MD STUDIO

# CLASSIQUE

## INTEMPORELLE ET RATIONNELLE

AGE FLAIR AND RATIONALITY

Fabrication tout aluminium, revêtement exclusif MAIORI, lignes tendues et profils épais, sans oublier de splendides coussins en tissu OTF...

**La collection Classique** s'inspire de l'élégance du château de Versailles en y ajoutant une note de rationalité moderne. Ornés de généreux coussins, ses canapés invitent à la relaxation en extérieur. De son côté, le fauteuil se combine facilement à toutes les tables à manger.

Grâce sa conception modulaire, la collection Classique offre différentes configurations en fonction du besoin d'espace. Grâce à un clip en U, les modules se connectent et se déconnectent facilement.

*Full aluminum body, MAIORI's signature coating, straight lines and thick profiles plus plentiful cushions on OTF fabric. **Classique series** is a combination of old Versailles' castle flair and modern rationality, the series features sofas with ample cushions and low height that are a study in outdoors relaxation, while the dining armchair can dress up a dining table effortlessly.*

*Classique modular design makes possible different configurations depending on spatial needs. The system design, with an U clip linking the modules, is easy and simple to install and remove.*





- ① CLASSIQUE SOFA WITH CUSHION - Light Taupe (A3) - Sable (E8)
- ② CLASSIQUE COFFEE TABLE - Light Taupe (A3)
- ③ CLASSIQUE RIGHT CHAISE LOUNGE - Light Taupe (A3) - Sable (E8)
- ④ LA LAMPE PAILLOTE





- ① CLASSIQUE COFFEE TABLE - Light Taupe (A3)
- ② CLASSIQUE LOUNGE CHAIR - Light Taupe (A3)
- ③ CLASSIQUE MODULE CUSHION - Sable (E8)



CL7971  
**Classique Champagne Coffee Table**  
14,1kg

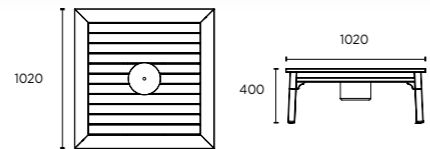

- A1
- A2
- A3
- A25

CL7839  
**Classique Coffee Table**  
13,5kg

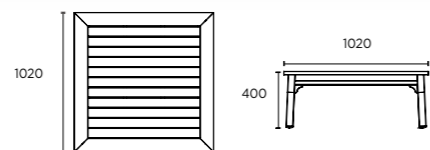

CL7981  
**Classique Lounge Chair With Cushion**  
14,1kg

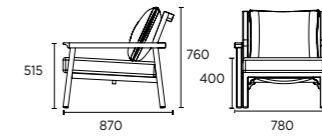

- A1
- A2
- A3
- A25
- E6
- E7
- E8

CL7972  
**Classique Sofa With Cushion**  
30,1kg

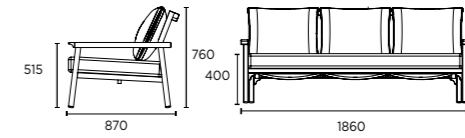

CL9605  
**Classique Center Module With Cushion**  
13,2kg

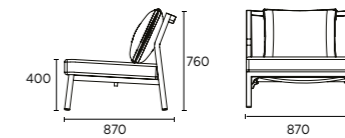

- A1
- A2
- A3
- A25
- E6
- E7
- E8

CL9606  
**Classique Right Module With Cushion**  
16,5kg

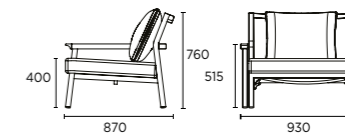

CL9608  
**Classique Left Module With Cushion**  
16,5kg

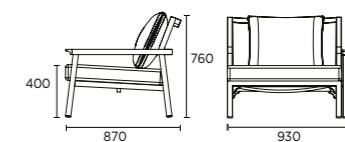

CL9603  
**Classique Corner Module**  
19,5kg

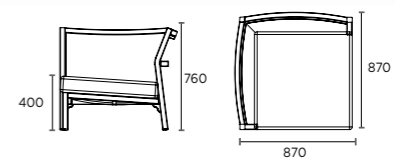

- A1
- A2
- A3
- A25
- E6
- E7
- E8

CL9607  
**Classique Ottoman**  
8,7kg

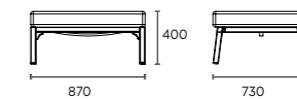

CL9609  
**Classique Left Chaise Lounge**  
20,3kg

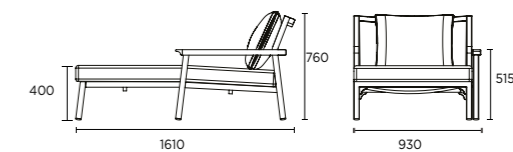

CL9610  
**Classique Right Chaise Lounge**  
20,3kg

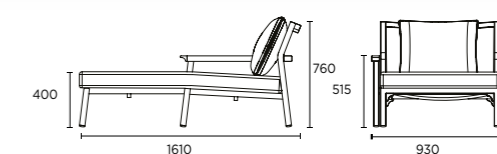

DESIGNED BY NORMAL STUDIO

# TRESSE

## LÉGÈRETÉ ET MODERNITÉ

LIGHTWEIGHT AND MODERN

Le dessin aérien de **la collection Tresse** est rendu possible grâce à une prouesse technique : celle de grand dossiers entièrement en porte-à-faux et qui semblent flotter. Dessinés comme un contour libre réalisé à main levée dans l'espace, ces dossiers signent la gamme d'assises et donnent à la collection Tresse sa légèreté et sa modernité.

Le motif du tressage imaginé par Normal Studio est inspiré d'un cannage traditionnel. Il se fait ici géométrique et se décline en perforation sur les plateaux en aluminium des tables. L'accent a été mis sur le confort avec un tressage en tension qui apporte soutien et flexibilité.

La collection se compose d'un canapé, d'un fauteuil bas et d'un bridge. Des tables basses rondes ou carrées et des tables à manger de différentes longueurs s'ajoutent aux assises et permettent de composer des salons d'extérieur complets.

*The Tresse collection's delicate filigree design is made possible by a remarkable technical feat: generous seatbacks that are entirely cantilevered, thus seeming to float in thin air. These seatbacks, designed like free-hand free-form contours in space, are the signature element of this seating line and give the Tresse collection its modern, lightweight appeal.*

*The original woven pattern created by Normal Studio takes its inspiration from traditional caning. Here, it is geometric in character, morphing to perforation for the tables' aluminium tops. Comfort was a design priority, with tension weaving that supports weight with gentle suppleness, for true wellbeing.*

*The collection includes a sofa, a low armchair and a bridge chair. There are also round and square coffee tables and dining tables of various lengths to combine with the seating options to assemble complete outdoor living spaces.*





- ① TRESSE DINING TABLE - White (A2)
- ② TRESSE DINING ARMCHAIR - White (A2)
- ③ LE PLATEAU - Charbon (A1)



TS9719  
**Dining Armchair**  
5,3kg

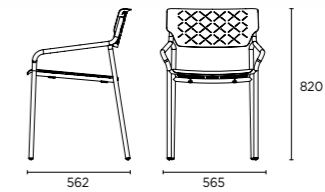

- A1
- A2
- A25



TS9729  
**Tresse Dining Table 80x80**  
16,5kg

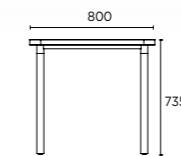

TS9726  
**Tresse Dining Square Table 100x100**  
18kg

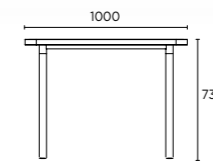

TS9727  
**Tresse Dining Rectangular Table 100x200**  
29,5kg

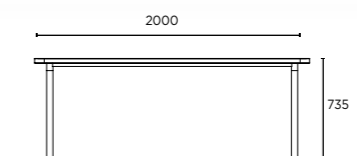

TS9730  
**Tresse Dining Long Table 100x300**  
41kg

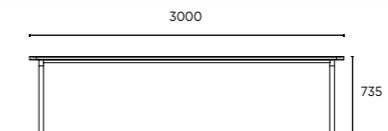



# IDYLL

## UNE COLLECTION QUI S'INSPIRE DU DESIGN SCANDINAVE.

A COLLECTION INSPIRED BY SCANDINAVIAN DESIGN.

Les lignes tendues des accoudoirs rejoignent le galbe léger des dossiers, les arêtes franches croisent les rondeurs des pieds... Fabriqué en Teck vieilli, **Idyll** bénéficie d'un traitement high-tech qui lui permettra de vivre de nombreuses années sans entretien particulier.

Les assises du salon Idyll sont généreuses dans leurs proportions. Les coussins ultras confortables épousent parfaitement les formes en teck et garantissent une durabilité extrême grâce à l'utilisation de mousse de haute densité et du tissu Sunbrella®.

Autour des tables carrées ou rectangulaires particulièrement sobres, les fauteuils Idyll viennent s'intégrer avec élégance et raffinement. De 4 à 8 places, la collection Idyll permet de composer des terrasses adaptées à l'organisation de chaque établissement.

*The stretched lines of the armrests join the light curve of the backrests, the clear edges cross rounded legs...Made of aged Teak, **Idyll** benefits a high-tech treatment allowing many years of life without special maintenance.*

*The Idyll living room seats are generous in their proportions. The ultra-comfortable cushions perfectly match the teak shapes and guarantee intensive use thanks to the use of high-density foam.*

*The Idyll armchairs fit with elegance and refinement the particularly sober square or rectangular tables. From 4 to 8 places, Idyll compose terraces suited to the organization of each establishment.*



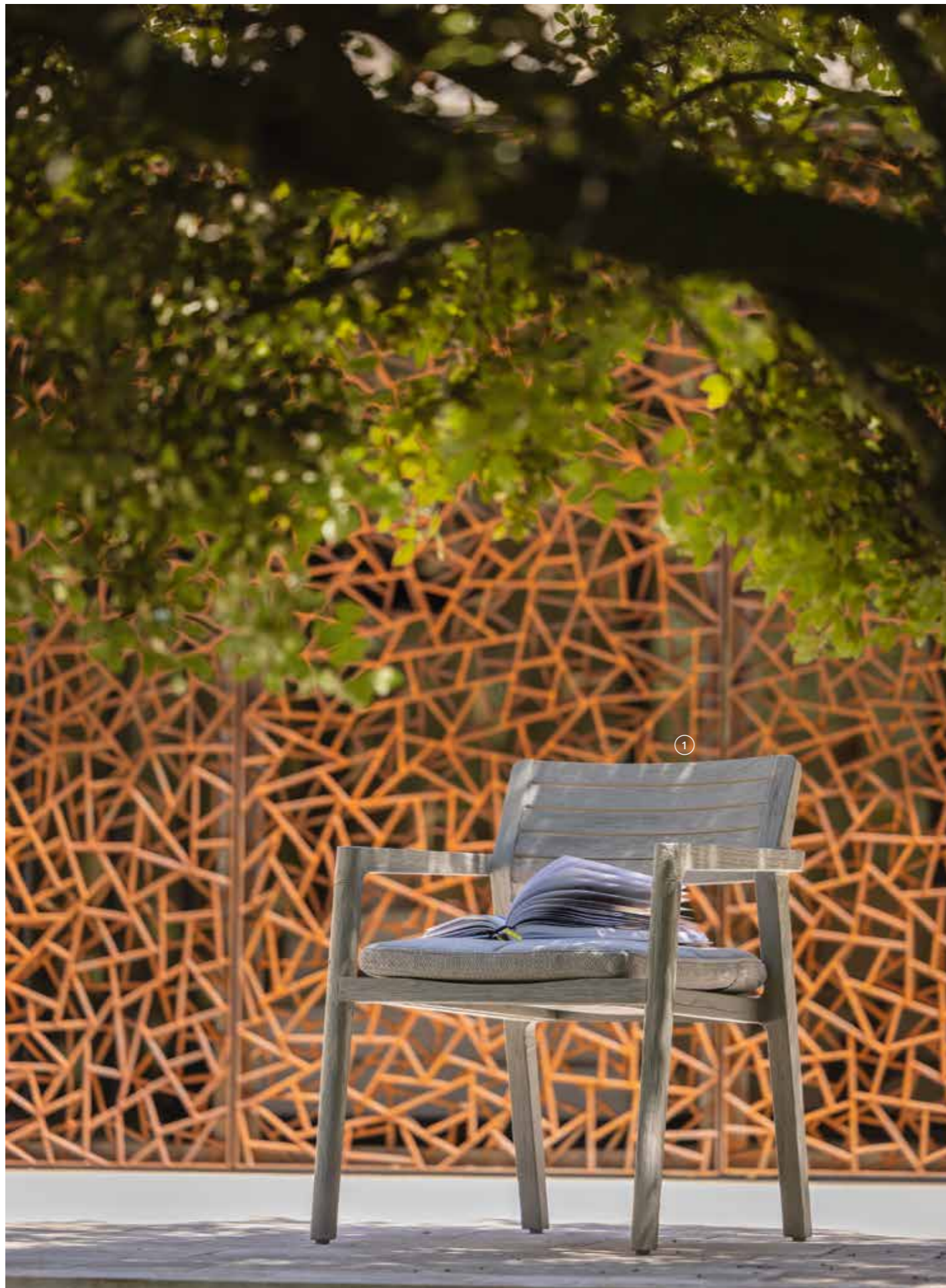



- ① IDYLL DINING ARMCHAIR - Vintage Grey (T3)
- ② IDYLL SOFA 180 - Vintage Grey (T3)



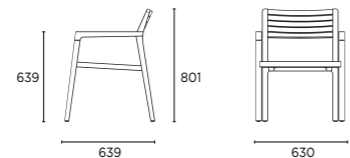

*IDY6198*  
**Idyll Dining Armchair**  
 7,1kg



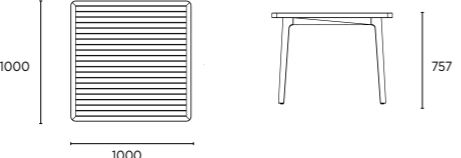

T1  
T2  
T3

*ID6197*  
**Idyll Dining Square table 100x100**  
 18,5kg

*ID6199*  
**Idyll Dining Rectangular table 100x200**  
 28,5kg

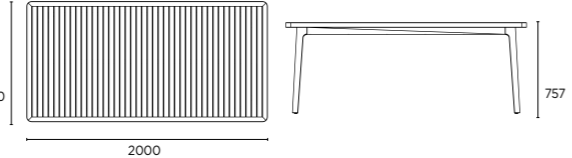

*ID5452*  
**Idyll High Side table 50x50**  
 6,5kg

*ID6195*  
**Idyll Low table 100x50**  
 8,8kg

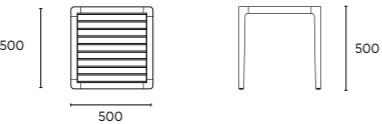

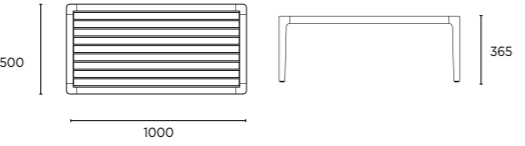

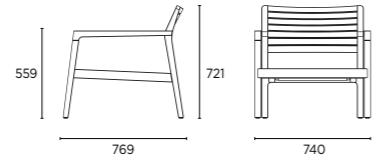
*ID6190*  
**Idyll Low Armchair**  
 13,5kg



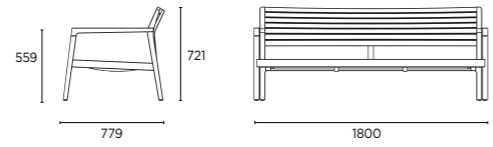

T1 AT04  
T2 AT05  
T3 AT06  
AT07

*IDY6192*  
**Idyll Sofa 180**  
 25,2kg

*IDY6257*  
**Idyll Ottoman**  
 6,2kg

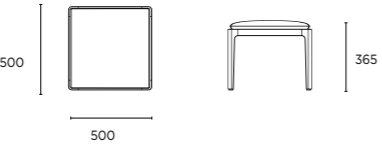
① IDYLL LOW ARMCHAIR - Vintage Grey (T3)  
 ② IDYLL LOW SIDE TABLE 50x50 - Vintage Grey (T3)

# KOSE

## ICONIQUE ÉLÉGANTE, MINIMALISTE

ICONIC, ELEGANCE, MINIMAL

Un fauteuil de café empilable, léger et vraiment différent : les courbes de **Kose** symbolisent le langage du design de Karim Rashid, tandis que l'aluminium thermolaqué et perforé nous rappelle qu'on est en présence d'un produit Maiori. Kose incarne l'émotion, la convivialité, l'humour, l'énergie positive et la dignité, des qualités humaines trop souvent absentes dans le design. Le résultat : un fauteuil de café empilable, léger et dans l'air du temps.

Avec sa silhouette iconique et minimaliste, Kose est un fauteuil élégant et qui sait rester abordable. Double symbole de fermeté et de flexibilité, Kose symbolise « L'INSTANT PRÉSENT ». Avec leur plateau repliable qui laisse passer la pluie grâce aux perforations en forme de gouttelettes, les tables incarnent à la perfection le design de mobilier de café, à la fois minimaliste et extrêmement fonctionnel. Karim Rashid : « Kose est vraiment cosy. Il propose un fauteuil de café empilable, compatible avec un usage en intérieur ou extérieur. Il est léger, confortable et capable d'affronter les éléments. » L'eau s'écoule à travers les perforations uniques en forme de gouttelettes, qui parcourent la surface en aluminium thermolaqué du fauteuil.

*Café Furniture Stackable, lightweight and truly different, **Kose's** curvy aspect embodies all of Karim's most recognizable design language, while the powder-coated aluminium, with perforated surfaces, adds the MAIORI trademark feel. Kose embodies human qualities like emotion, usability, humour, positive energy, and proud spirit that are so often missing from design, resulting in a stacking café armchair that is lightweight and current.*

*Kose strikes an iconic, minimal silhouette, serving elegance while remaining affordable. Simultaneously embodying firmness and flexibility, Kose represents the NOW". Kose tables, with collapsible tabletops featuring blob-shaped perforations to let the rain trespass, are an example of understated and extremely utilitarian café design. In Karim Rashid's words: "Kose more than lives up to its name. A stacking café armchair that addresses the needs of both indoor and outdoor use, Kose armchair is lightweight, comfortable, and durable against the elements. It boasts unique blob-shaped perforations in its powder-coated aluminium form, allowing for water to flow through the chair rather than accumulate.*





KE6060  
**Kose Armchair**  
4,0kg

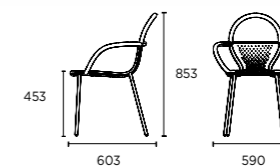

KE6061  
**Kose Square Bistro Table**  
20,0kg

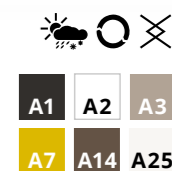
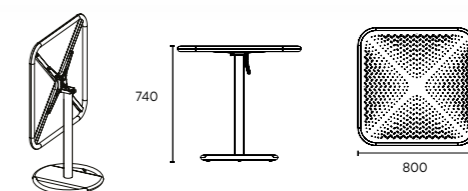

KE6062  
**Kose Round Bistro Table**  
17,0kg

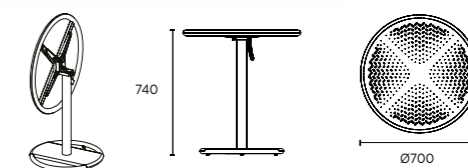

DESIGNED BY MD STUDIO

# VEGA

## DU MOBILIER FACILE À VIVRE

FURNITURES EASY TO LIVE WITH

De par sa plasticité et sa pose légère, **Vega** est un objet facile à vivre. Peu exigeant, élégant et facile d'entretien, Vega est une invitation immédiate à la détente. Grâce à son style contemporain et à sa polyvalence, Vega habille parfaitement les restaurants et cafés, en intérieur comme en extérieur. Derrière l'apparence légère et gracieuse de Vega se cache une construction robuste, faite pour durer et résister aux intempéries ainsi qu'aux conditions d'utilisation les plus sévères.

Tous les cadres et plateaux Vega sont fabriqués en aluminium recyclable et revêtus d'une élégante couche d'époxy durcie au four, la peinture la plus propre et écologique à ce jour. Tout aluminium, osier, Batyline ou Batyline rembourré : avec son large choix de déclinaisons pour l'assise et le dossier, Vega représente l'option de mobilier extérieur la plus complète et personnalisable.

*The plasticity and light pose of **Vega** makes for an easy object to live with. Undemanding, elegant and carefree, Vega puts you at ease, so you can relax. Vega's contemporary flair and versatility makes it also a great choice for in-out dinner and café furniture. At first sight, Vega is light and graceful, but underneath the skin there is a heavy-duty object concealed which is purely engineered to perform and withstand even the most unforgiving conditions, whatever the abuse or weather conditions.*

*All Vega frames and tabletops are made on recyclable aluminium and finished with a handsome layer of oven cured epoxy, the cleanest and environmentally friendly paint known. A choice of Full Aluminium, Wicker, Batyline or padded Batyline choices is available for the seat and backrest, making Vega the one most comprehensive and customizable outdoor furniture option.*





- ① VEGA PADDED SLING CHAIR - Cafe (A14) - Cafe (P14)
- ② LA LAMPE PAILLOTE
- ③ VEGA TABLE 90x90 - Cafe (A14)
- ④ VEGA ALUMINIUM ARMCHAIR - Cafe (A14)
- ⑤ LA LAMPE PARC - White (A2)
- ⑥ LA LAMPE PADERE - White (A2) - Lemon (F10)







VG8087-04  
**Vega Sling Chair**  
2,7kg

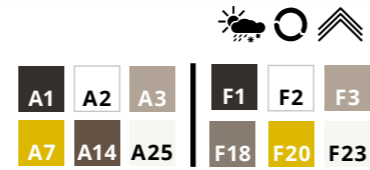
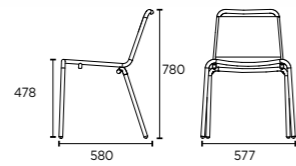

VG8087-04C  
**Vega Padded Sling Chair**  
2,8kg

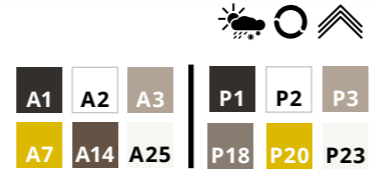
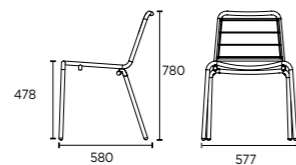

VG8087-02  
**Vega Aluminium Chair**  
4,3kg

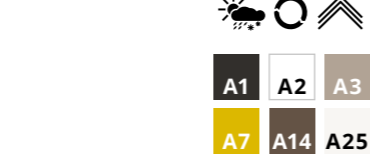
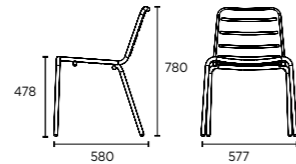

VG8086-04  
**Vega Sling Armchair**  
3kg

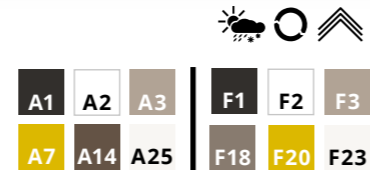
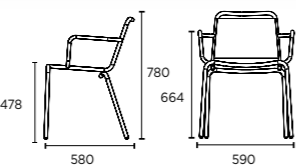

VG8086-04C  
**Vega Padded Sling Armchair**  
3,1kg

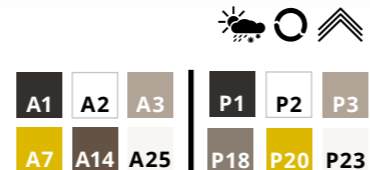
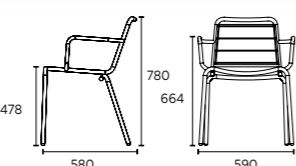

VG8086-02  
**Vega Aluminium Armchair**  
4,7kg

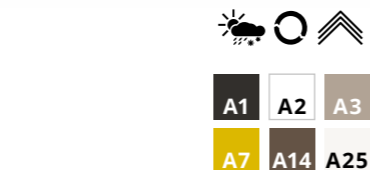
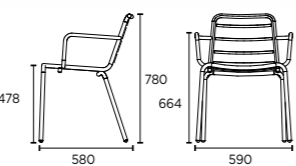

VG8126  
**Vega Sling Bar Chair**  
3,1kg

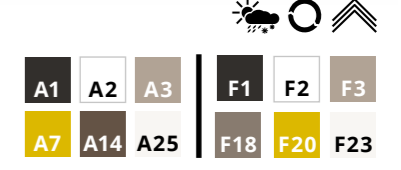
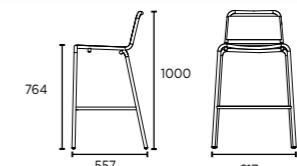

VG8126  
**Vega Padded Sling Bar Chair**  
3,2kg

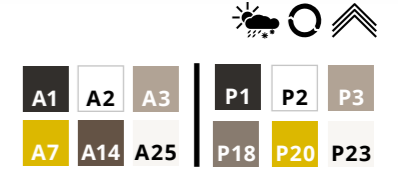
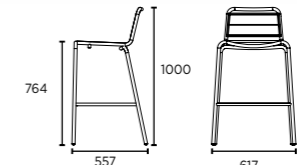

VG8126  
**Vega Aluminium Bar Chair**  
5,0kg

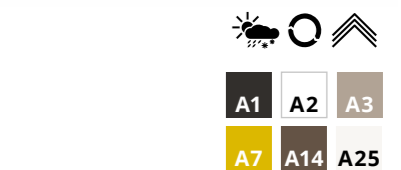
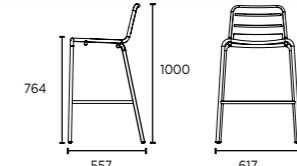

VG8123  
**Vega Sling Bar Armchair**  
3,6kg

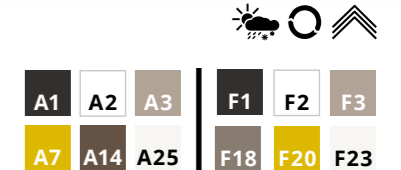
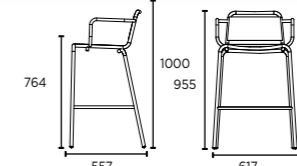

VG8123  
**Vega Padded Sling Bar Armchair**  
3,7kg

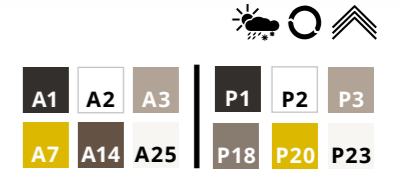
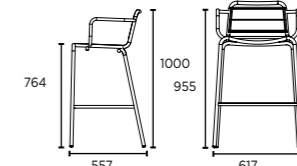

VG8123  
**Vega Aluminium Bar Armchair**  
5,6kg

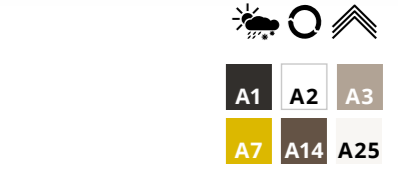
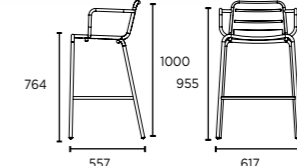

VG6300  
**Vega Dining chair Seat and Backrest Cushion**  
0,5kg

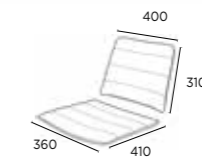



VG8127  
**Vega Table**  
**90x90**  
 12,9kg

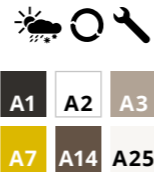
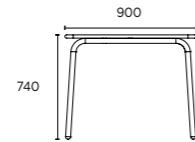

VG6101  
**Vega Table**  
**90x180**  
 22,7kg

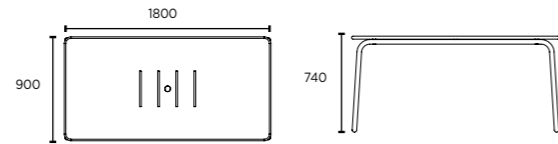

VG8105  
**Vega Bistro Table**  
**80x80**  
 20,7kg

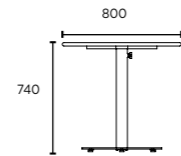

VG8107  
**Vega Bistro Table**  
**Ø80**  
 20,4kg

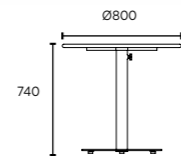

VG6100  
**Vega Bar Table**  
**80x80**  
 20,7kg

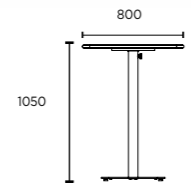

VG8121  
**Vega Bar Table**  
**Ø80**  
 20,7kg

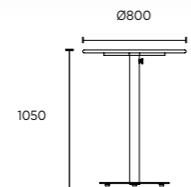

VG6102  
**Vega Extension Table**  
**100x200(300)**  
 48,6kg

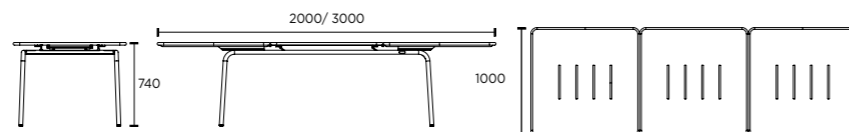

- ① VEGA ALUMINIUM BAR ARMCHAIR - Cafe (A14)
- ② VEGA BAR TABLE - Cafe (A14)
- ③ LA LAMPE PARC - White (A2)

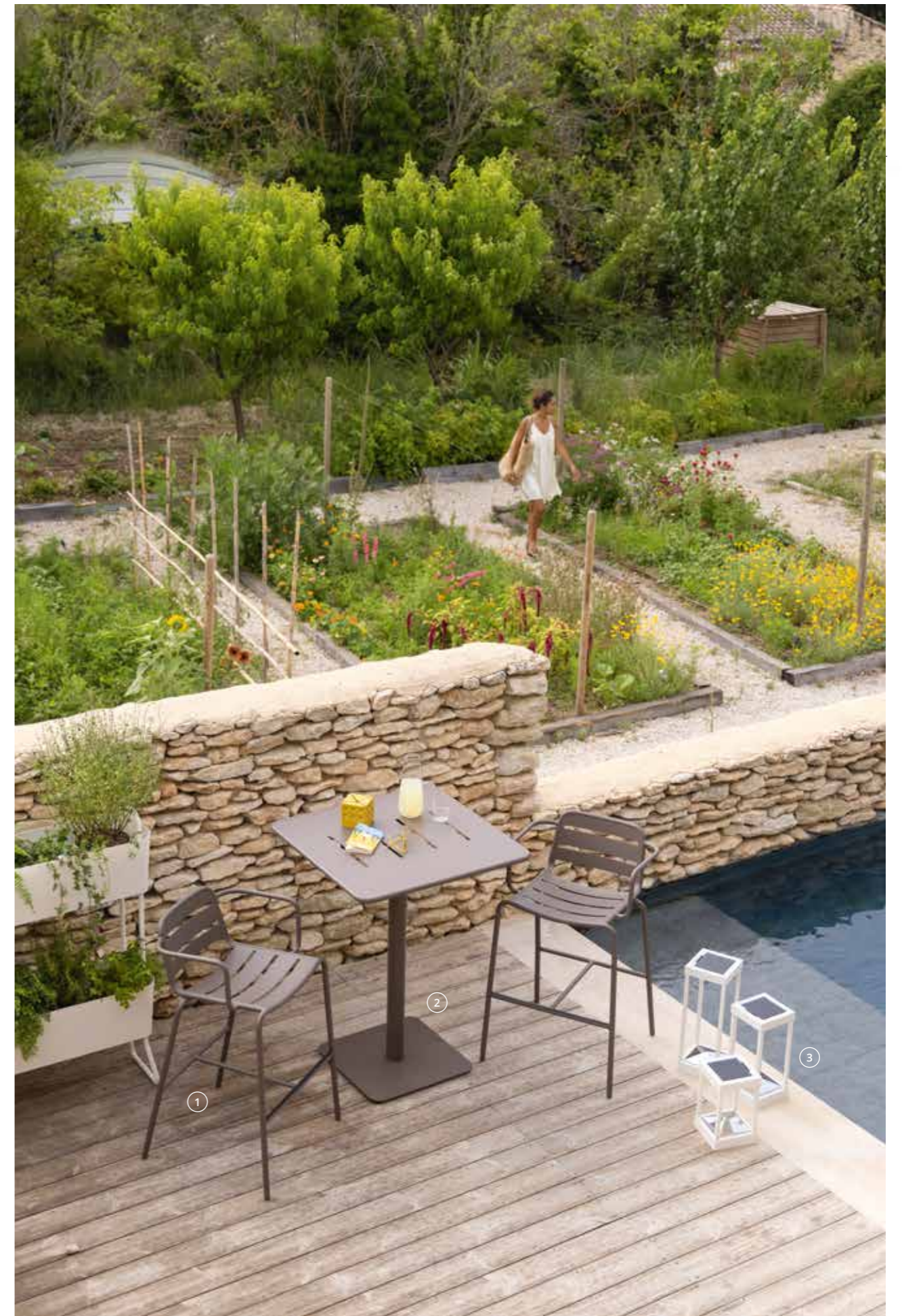

# INITIAL

## INSPIRÉE DU CONFORT ET DU DESIGN ORIENTAL

INSPIRED BY COMFORT  
AND ORIENTAL DESIGN

Les modules **Initial** permettent de composer des ensembles au gré de ses envies ou de ses besoins grâce à un système de dossiers escamotables exclusif. Avec une profondeur d'assise hors norme, toute la gamme appelle au farniente et à la convivialité.

Les tables basses assorties ont été conçues dans les mêmes proportions que les modules d'assises afin d'offrir une composition particulièrement bien structurée. Ainsi, les dimensions de la collection Initial permettent la création de salons de toutes les tailles en respectant une organisation structurée.

Le sofa Initial se caractérise par sa plateforme en teck recouverte d'une patine pour un effet « vintage ». Grâce à sa construction modulaire et un système de dossiers escamotables, les modules Initial répondent aux souhaits les plus individuels en matière d'agencement. Avec une profondeur d'assise hors norme, toute la gamme appelle au farniente et à la convivialité.

La table basse Initial se caractérise par son plateau en teck recouvert d'une patine pour un effet « vintage ». Belle et généreuse, elle complètera parfaitement la gamme de la collection Initial.

*Initial modules allow to create sets matching all needs and desires, thanks to an exclusive retractable backrest system. With an extraordinary seat depth, the whole range calls for relaxation and conviviality.*

*Assorted Coffee Tables have been designed with the same proportions as the seating modules to provide a particularly well-structured composition. Thus, the dimensions of the Initial collection allow the creation of salons of all sizes while respecting a structured organization.*

*The sofa Initial is characterized by its teak platform covered with a patina for a «vintage» effect. Thanks to its modular construction and retractable backrest system the Initial modules fulfill the most individual wishes in terms of layout. With an extraordinary seat depth, the whole range calls for relaxation and conviviality.*

*The coffee table INITIAL is characterized by its teak tray covered with a patina for a «vintage» effect. Beautiful and generous, it will perfectly complement the range of the INITIAL collection.*





- ① INITIAL PLATFORM TABLE - Vintage Brown (T2)
- ② INITIAL PLATFORM 90x90 - Vintage Brown (T2)
- ③ LA LAMPE POSE 04 - Moutarde (A7)
- ④ INITIAL PLATFORM 180x90 - Vintage Brown (T2)



①



②

- ① INITIAL COFFEE TABLE - Vintage Brown (T2)
- ② INITIAL PLATFORM 180x90 - Vintage Brown (T2)



IN6158  
**Initial Coffee Table**  
17,4kg

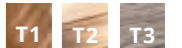
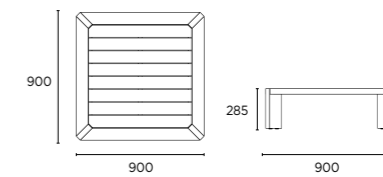

IN6143  
**Initial Ottoman 900x900**  
17,5kg

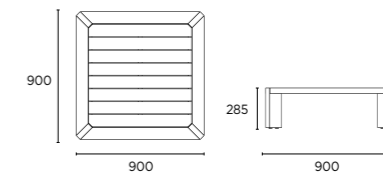

IN6157  
**Initial Corner 900x900**  
18,4kg

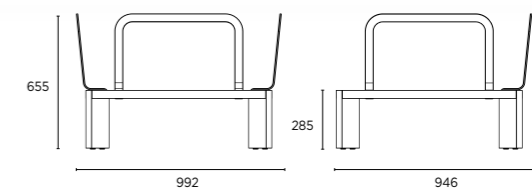

IN6159  
**Initial Platform 1800x900**  
29kg

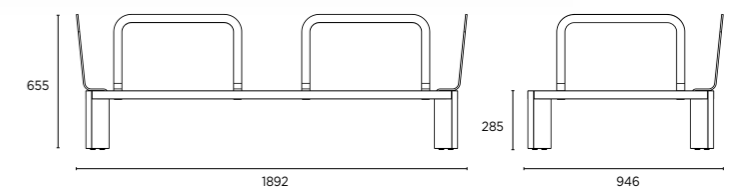

# A600

## LE CHIC INDUSTRIEL À LA FRANÇAISE

FRENCH INDUSTRIAL CHIC

Véritable condensé des meilleures pratiques de design, la collection **A600** de MAIORI est née de l'esthétique légère et indulgente proposée par Christophe Pillet. Conçue pour l'extérieur mais parfaitement utilisable en intérieur, cette collection insouciance a tout ce qu'il faut pour devenir un classique contemporain. Saisir la substance charismatique d'un jardin à la française et la traduire dans une proposition intemporelle : tel est le concept de la collection A600 et de ses points de vue subtils et indulgents signés Christophe Pillet. Un condensé des meilleures pratiques de design et un dialogue de contrastes.

Conçue pour le jardin, la collection A600 s'intègre pourtant parfaitement dans un environnement intérieur, grâce à ses impeccables proportions, son style contemporain et ses lignes aussi pures qu'élégantes.

Saisir la substance charismatique d'un jardin à la française et la traduire dans une proposition intemporelle : tel est le concept de la collection A600, matérialisé par les points de vue subtils et indulgents du concept de chaise A600 signé Christophe Pillet.

*The light, forgiving looks of Christophe Pillet A600 Series for MAIORI are an account of design best practices. Created for the outdoors and with vocation for the indoor, this playful series of tables and seating are set to become a contemporary classic. The idea of capturing the charismatic substance of the French back garden in a timeless proposal sets the mood for the A600 series, an idea crystalized in the petite, forgiving looks of Christophe Pillet's conception that is an account of design best practices and a dialogue of contrasts.*

*A600 Series is conceived with the garden in mind, it performs swiftly indoors. The proportions used, its cleanness, flair, and the contemporaneous of its lines makes it impeccable for use in indoor space*

*The idea of capturing the charismatic substance of the French back garden in a timeless proposal sets the mood for the A600 collection, an idea crystalized in the petite forgiving looks of Christophe Pillet's A600 Chair conception.*

- ① A600 OTTOMAN - Woven White (A2)
- ② A600 SOFA - White (A2-C10)
- ③ A600 LOW TABLE - White (A2)
- ④ A600 OTTOMAN - White (A2-C10)

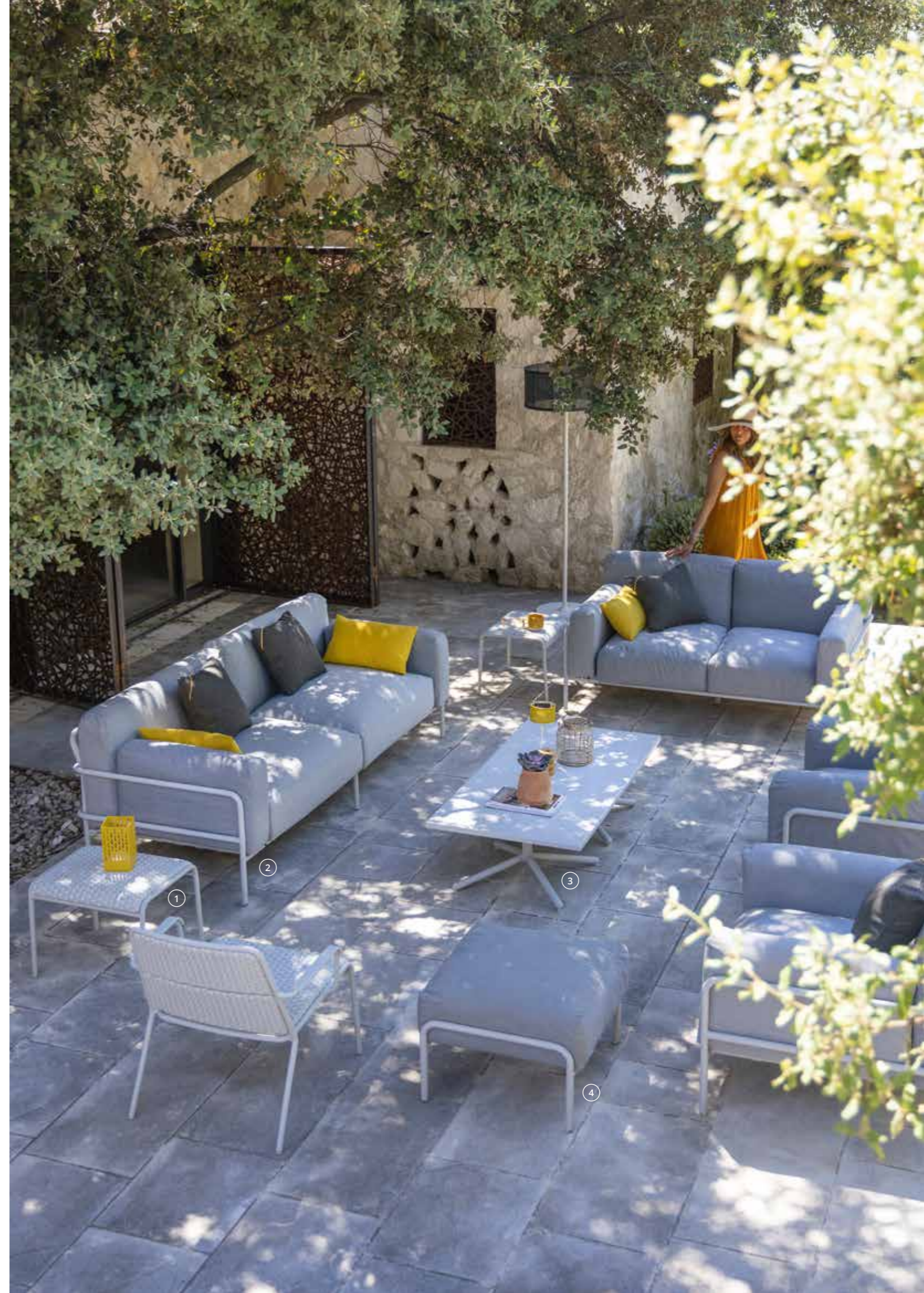



- ① A600 TABLE 90x180 - White Pearl (A25)
- ② A600 BENCH - White Pearl (A25) - White Pearl (WF29)
- ③ A600 LOW ARMCHAIR - White Pearl (A25) - White Pearl (WF29)
- ④ A600 CHAIR - White Pearl (A25)
- ⑤ A600 TABLE 90x90 - Charbon (A1)
- ⑥ LA LAMPE PADERE - Charbon (A1) - Charbon (F1)









- ① A600 BENCH - Charbon (A1)
- ② A600 BISTRO TABLE - Charbon (A1)
- ③ A600 BENCH - Charbon (A1)

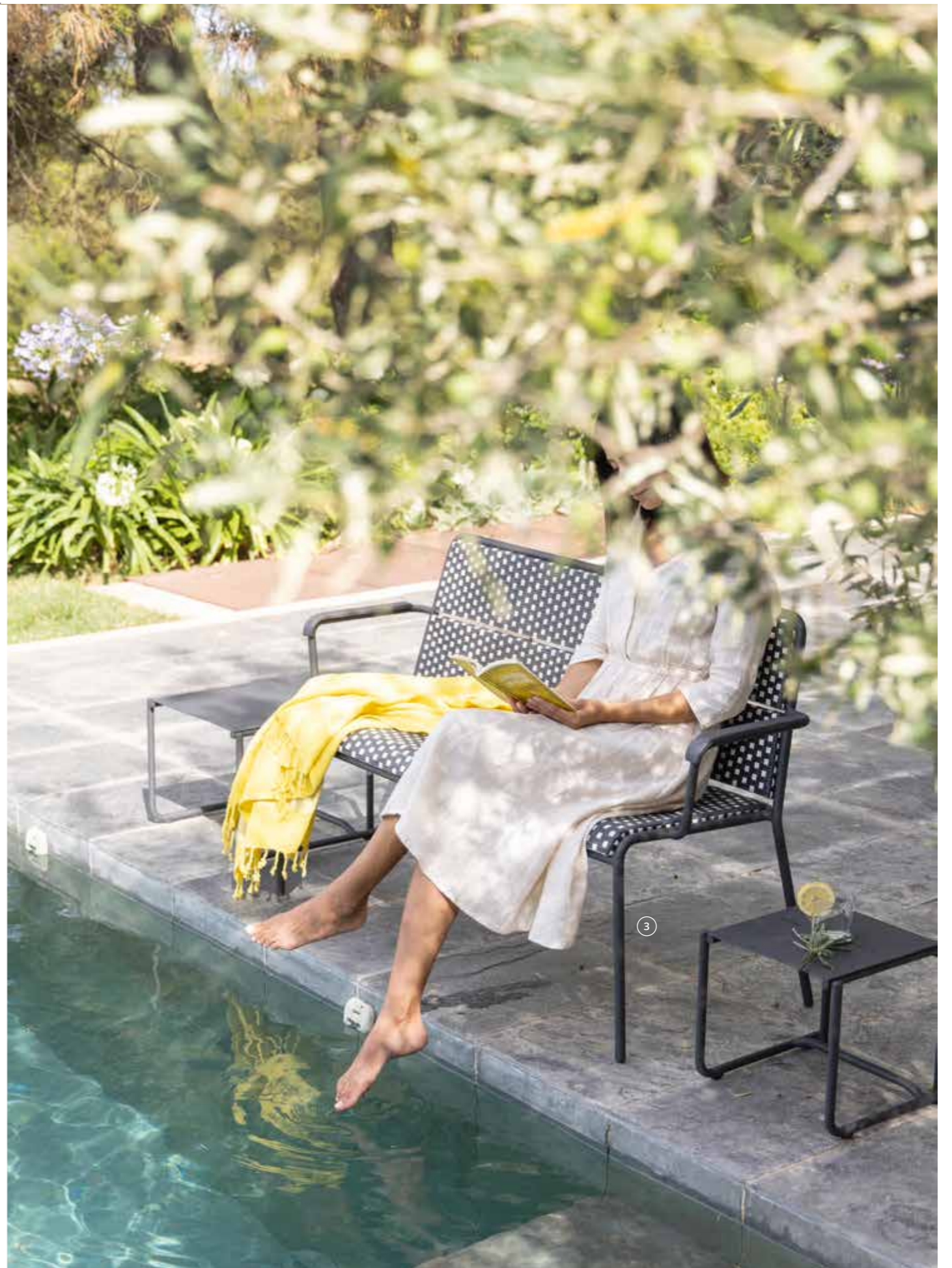



CP9106  
**A600 Chair**  
4,7kg

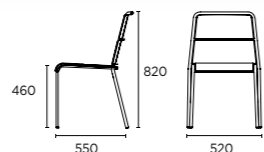

Structure / Frame  
A1 A2 A3 A7 A25

Assise & Dossier / Seat & Back  
A1 A2 A3 A7 A25

WF28 WF30 WF31 WF29



CP9102  
**A600 Armchair**  
5,5kg

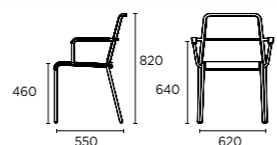

CP9111  
**A600 Bench**  
12,0kg

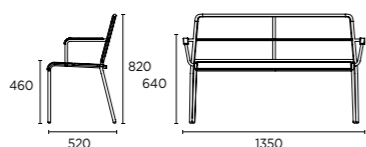

CP9100  
**A600 Lounge Chair**  
6,4kg

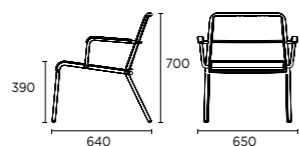

CP9103  
**A600 Ottoman**  
3,2kg

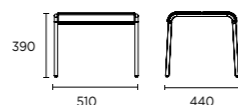

CP6301  
**A600 Seat and Backrest Cushion for Chair**  
0,5kg

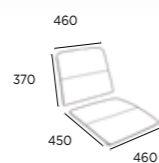

AT01 AT02



CP6303  
**A600 Seat and Backrest Cushion for Lounge Chair**  
0,7kg



CP9105  
**A600 Bistro Table**  
8,3kg

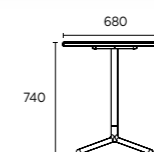

A1 A2 A7 A25



CP9110  
**A600 Table 90x90**  
17,3kg

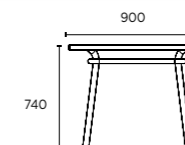

CP9632  
**A600 Table 90x180**  
24,2kg

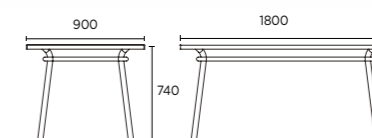

CP9112  
**A600 Extension Table 100x160(200)**  
38,8kg

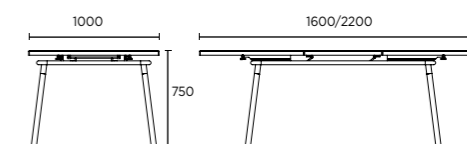

CP9121  
**A600 Low Armchair**  
20,0g

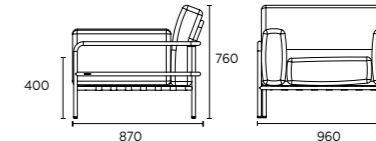

A1 AT01  
A2 AT02  
A25 AT05  
AT06



CP9123  
**A600 Sofa**  
28,2kg

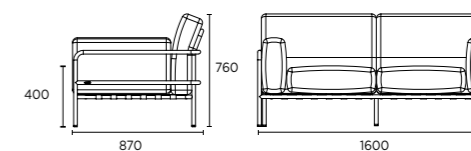

CP9126  
**A600 Ottoman**  
6,5kg

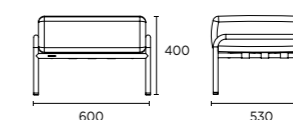

CP9630-02  
**A600 Low Table 68x68x35**  
8,2kg

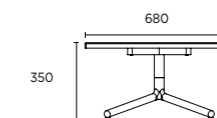

A1  
A2

# MICA

## UNE CHAISE IRRÉVÉRENCIEUSEMENT SUBURBAINE

THE ONE IRREVERENTLY SUBURBAN CHAIR

Inattendu, détendu et résolument suburbain : conçu par les maîtres du design industriel de MAIORI Design Studio, **Mica** est fondé sur les principes de l'utilitarisme : un bon design est une question d'honnêteté, et non de luxe. Fabriquée selon de rigoureux critères de durabilité, la chaise Mica offre un corps tout aluminium T6, élégamment cintré et embouti, et fini avec un revêtement en poudre durci au four. Le choix de matériau s'avère idéal pour la cuisine, le salon et le plein air.

Élégant mais indestructible, le modernisme de Mica est tout à la fois une singularité éclectique et une proposition exceptionnelle. Audacieuse par sa forme, la chaise Mica communique l'optimisme, à contre-courant radical de l'ennui et de la monotonie de ses homologues contemporaines.

*Unexpected, relaxed, irreverently suburban... Designed by the industrial design maestros at MAIORI Design Studio, Mica was conceptualized under the principles of utilitarianism. Declaring that good design must be an honest deal, not a luxury. Produced under rigorous sustainable standards, Mica offers a full aluminium T6 body, skillfully bent and stamped, and finished with oven cured powder coating. This material choices brands it perfect for use in the kitchenette, the lounge or al fresco.*

*Elegant yet indestructible, Mica's modernism is an eclectic oddity and an exceptional proposal. Its shape transmits optimism for its boldness, indicating a fun radical departure from the dullness and monotony of its contemporary counterparts.*





- ① LA LAMPE POSE 02 - Light Taupe (A3)
- ② GREENS TRIO - White (A2)
- ③ A600 BISTRO TABLE - White (A2)
- ④ MICA WOVEN CHAIR - White Pearl (A25-WF29)



M19073  
**Mica Woven Chair**  
4,2kg

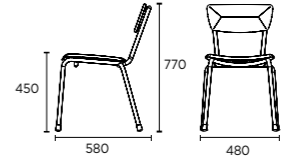

☀️ 🌧️ 🏠

A1	A3	WF28
A7	A25	WF29
		WF30
		WF31



M19167  
**Mica Woven Armchair**  
4,7kg

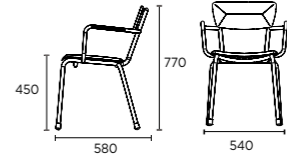

M19060  
**Mica Chair**  
3,9kg

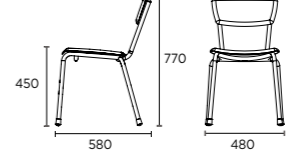

☀️ 🌧️ 🏠

A1	A3
A7	A14
A25	



M19166  
**Mica Armchair**  
4,4kg

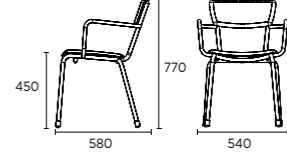

DESIGNED BY MD STUDIO

# NC

## DESSIN ULTRALÉGER

ULTRALIGHT DESIGN

Aussi légère que résistante, **la collection NC** est un assemblage subtile de tube d'aluminium rond et de toile Batyline SF. Son aspect discret et presque transparent la rend naturellement élégante.

Ce mobilier appelle à la relaxation et s'accordera parfaitement en terrasse, patio et en bord de piscine.

*Ultralight, yet hard-wearing, the NC Series expert mix of thin aluminium round tube and Serge Ferrari Batyline gives NC series a lean and almost see-through aspect, making it naturally elegant and understated.*

*This furniture calls for relaxation and is perfect for terraces, patios and poolside areas.*





- ① NC HIGH TABLE 90x180 - Light Taupe (A3)
- ② NC HIGH CHAIR - Light Taupe (A3 - F3)
- ③ NC ARMCHAIR - Light Taupe (A3 - F3)
- ④ NC TABLE 90x180 - White (A2)
- ⑤ NC ARMCHAIR - White (A2 - F2)
- ⑥ LIGHT TRAY - White (A2)



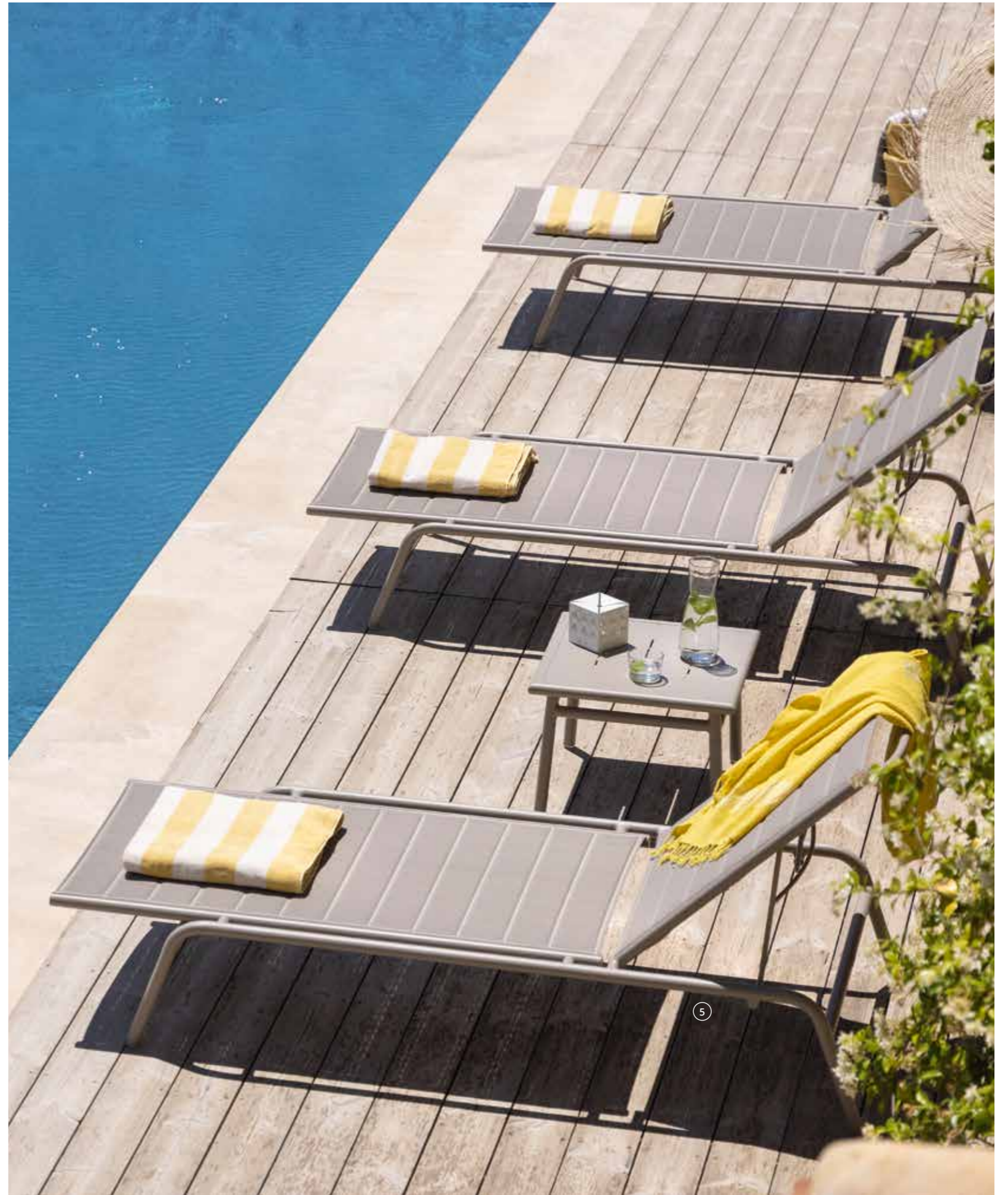

- ① LA LAMPE POP UP - Charbon (A1)
- ② LA LAMPE POSE 02 - Moutarde (A7)
- ③ NC SUN LOUNGER - White (A2 - P2)
- ④ NC SIDE TABLE - Light Taupe (A3)
- ⑤ NC SUN LOUNGER - Light Taupe (A3 - P3)



NC9155  
**NC Chair**  
2,9kg

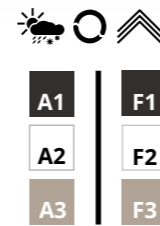
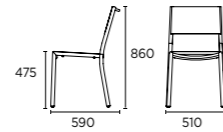

NC9153  
**NC Armchair**  
3,4kg

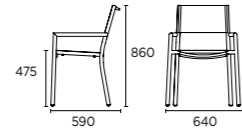

NC8733  
**NC High Chair**  
3,5kg

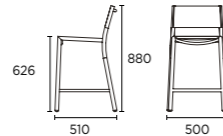

NC8715  
**NC Sun Lounger**  
9,6kg

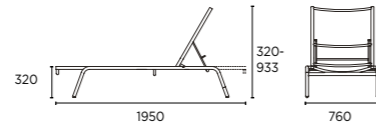

NC8670  
**NC Table 90x90**  
12,2kg

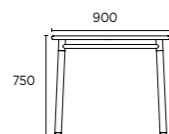

NC8682  
**NC Table 90x180**  
20,5kg

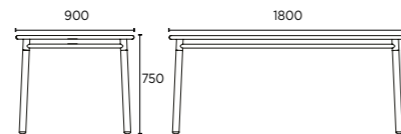

NC8671  
**NC High Table 90x90**  
12,7kg

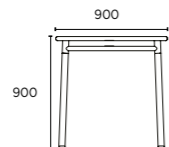

NC8683  
**NC High Table 90x180**  
21kg

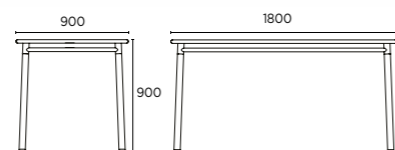

NC8714  
**NC Side Table**  
4,7kg

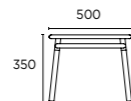

NC8975  
**NC Side Pocket**  
0,1kg

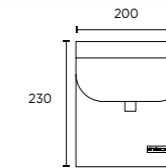

NC8973  
**NC Headrest**  
01kg

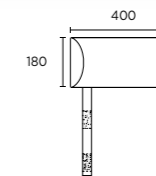

NC8978  
**NC Wheel (2pcs/ set)**  
0,1kg



NC8976  
**NC Clip Table**  
2,4kg

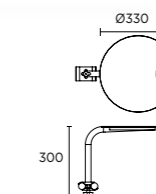

NC8977  
**NC Foot Plate (4pcs/ set)**  
0,1kg





# LA WATCHAIR

## LA CHAISE D'ARBITRE MODULABLE

THE MODULAR UMPIRE'S CHAIR

Maiori complète sa gamme de mobilier ludique et original avec **la Watchair**.

Véritable chaise d'arbitre modulable, la Watchair s'habille de différents accessoires, afin de s'adapter au mieux à son environnement.

Vêtue de vert pour les courts de tennis, de bleu pour les piscines et de rouge pour les plages, une chose est sûre, la Watchair ne passera pas inaperçue.

Disponible en single ou en duo, et en deux hauteurs, la Watchair est votre nouvelle alliée pour voir la vie d'en haut.

*Maiori has added **the Watchair** to its range of fun and original furniture.*

*A genuine modular umpire's chair, the Watchair can be dressed up with different accessories to adapt to its environment.*

*Dressed in green for tennis courts, blue for swimming pools and red for beaches, one thing is certain, the Watchair will not go unnoticed.*

*Available as a single or duo, and in two heights, the Watchair is your new ally in seeing life from above.*



NC8696  
**Watchair  
Single**  
17kg

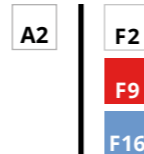
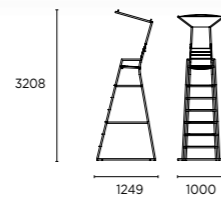

NC8932  
**Watchair  
Double**  
26kg

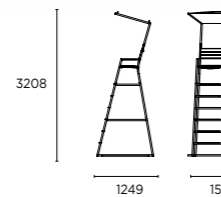

# LIGHT TRAY

## UNE DESSERTE DE JARDIN EN ALUMINIUM

AN ALUMINIUM GARDEN TROLLEY

Le **Light Tray** est une desserte multi-plateaux en colonne verticale. Ce produit marque le début d'une nouvelle gamme de produits meublant utiles, pratiques et éclairants grâce à notre module solaire hybride. Il se compose d'un plateau amovible, d'un porte-verres et d'un sceau à glace, le tout facilement transportable grâce à sa poignée intégrée. Un emplacement a été spécialement étudié pour y glisser un module solaire et hybride offrant alors un faisceau de lumière périphérique qui permet une utilisation à la nuit tombée et offre jusqu'à 10h d'autonomie. Un accessoire de service pour l'extérieur ou l'intérieur, pratique et ludique pour des soirées réussies et lumineuses. Il se décline dans 3 couleurs, charbon, blanc et un bicolore café/taupe clair.

\* Le Module Hybrid S n'est pas inclut avec le Light Tray mais est disponible séparément.

*Le **Light Tray** is a vertical column with several shelves. This product marks the beginning of a new range of useful, practical and light furniture thanks to our hybrid solar module. It consists of a removable tray, a glass holder and an ice bucket, all of which can be easily transported thanks to its integrated handle. A slot has been specially designed to accommodate a solar and hybrid module, providing an all-round light beam for use after dark and offering up to 10 hours of autonomy. A practical and playful outdoor or indoor service accessory for successful and bright evenings. It is available in 3 colours, charcoal, white and two-tone coffee/light taupe.*

*\* The Hybrid S module is not included with the Light Tray but is available separately.*



LP6588  
**Light Tray**  
3,8kg

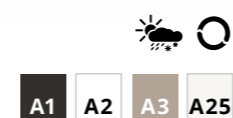
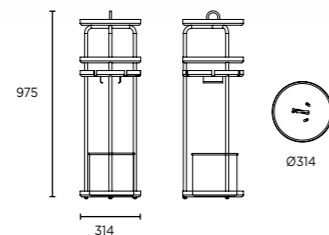

DESIGNED BY MD STUDIO

# GREENS

## UN VÉRITABLE JARDIN DANS UN ESPACE MINIME

*BIG GARDEN, MINIMUM FOOTPRINT*

Vous aimeriez recréer un coin de jungle sur votre petit balcon ? Bonne nouvelle, avec **la Collection Greens**, 0,3m<sup>2</sup> suffisent. Cette ingénieuse structure verticale à bacs, mise au point par le studio de design MAIORI, dessine les lignes d'un jardin vertical minimaliste, qui permet un arrosage par égouttement de l'eau du haut vers le bas, éliminant tout risque d'arrosage excessif.

Le système de jardin vertical Greens ( VGS - Vertical Garden System ), parce qu'il est modulaire, permet des combinaisons de hauteurs et couleurs infinies.

*If you have 0.3 square meters of floor space you have a garden, seriously.*

**Greens Maxi** gives you 4 levels of chic vertical gardening to express yourself. Designed as a simple drip watering system, it allows water to flow from top to bottom, eliminating water paddles and overwatering, so it ideal for interior spaces, but not only.

*Greens Maxi, with two and half meters of height, can cover your entire wall from top to bottom, and unlike most of the vertical garden systems, it is easy to install. And if you need a rest from it, or need to move, just disassemble it and see that it all fits stacked in the space of just one single pot.*





GR9177P1  
**Greens Mini**  
 6,4kg

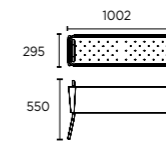

GR9177P2  
**Greens Duo**  
 12,3kg

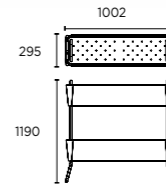

GR9177P3  
**Greens Trio**  
 18,4kg

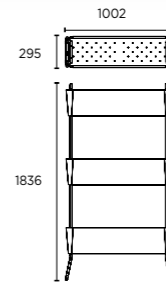

GR9177P4  
**Greens Maxi**  
 24kg

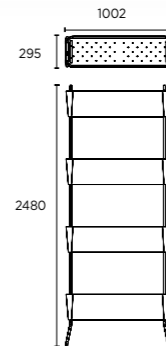

GR9187  
**Greens Water Tray**  
 0,5kg

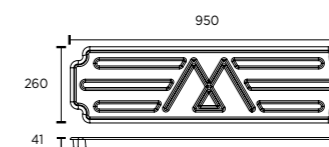

DESIGNED BY MD STUDIO

# LE PLATEAU

## RÉVERSIBLE EN ALUMINIUM

REVERSIBLE IN ALUMINIUM

Toujours dans l'idée d'accessoiriser sa gamme, Maiori propose le plateau réversible en aluminium. Disponible en charbon et blanc avec un choix de set de table de différentes couleurs.

*In keeping with the idea of accessorising its range, Maiori offers the reversible aluminium tray. Available in charcoal and white with a choice of placemats in different colours.*



LP7707

**Le Plateau**  
1,5kg

80

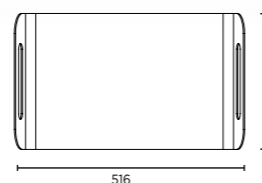

305

516

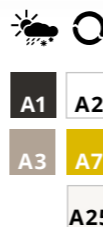

DESIGNED BY MD STUDIO

# LES SETS

## DE TABLE

### PLACEMATS

**Le set de table** Maiori est spécialement conçu pour une utilisation en extérieur, grâce à un tissu technique résistant et facile d'entretien. Il peut être utilisé sur le plateau et s'accordera parfaitement avec les lampes Pose et Popup.

*Maiori placemat is made with spécial Outdoor fabricant Batyline, résistant and easy-care. It colours will mix and match the Pose & Popup collections and it can be use with the Tray.*

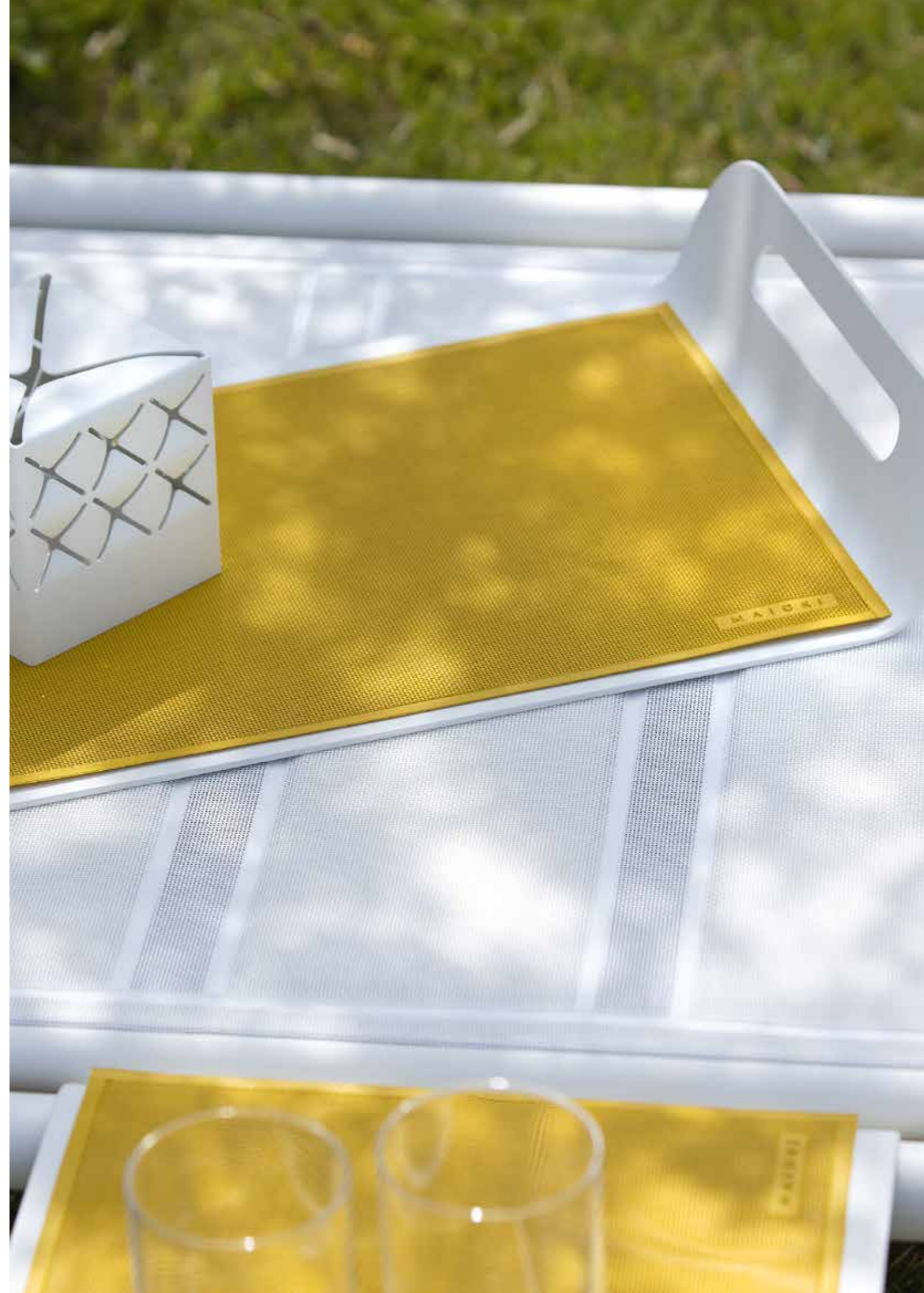

MAT9117  
**Placemats**  
0,2kg

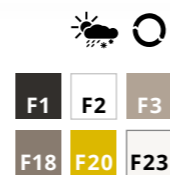
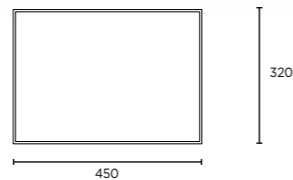



# MATÉRIAUX & COULEURS

MATERIALS & COLORS



# 100% RECYCLABLE ALUMINIUM

POWDER COATED





**MAIORI** utilise de l'aluminium de première fonte et de grade marine pour concevoir des structures solides, légères et inaltérables. Son excellente résistance à la corrosion en fait un matériau idéal pour une utilisation extérieure.

Le revêtement en poudre est appliqué de manière électrostatique et durci sous très haute température, il permet une parfaite répartition du composant sur toute la surface du métal. Cette finition permet de prévenir des impacts et de résister à l'humidité et la corrosion.

**MAIORI** uses the marine grade aluminium to produce robust yet lightweight structures. Its excellent corrosion resistance makes it an ideal material for outdoor use. Pre-treated with chrome coating provides optimum protection for aluminium that is constantly exposed to humid and salty environmental before being powder coated.

The powder coating is applied electrostatically and cured at very high temperature which ensures that there is 100% coverage of the metal's surface. It gives a consistent and tough finish that far exceeds other conventional paint finishes. The finishing is crack and scratch resistant, impervious to moisture and highly resistant to corrosion.

## ALUMINIUM ( A ) - COULEURS / COLORS

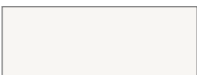
	A1 / CHARBON
	A2 / BLANC
	A3 / LIGHT TAUPE
	A7 / MOUTARDE
	A14 / CAFE
	A25 / WHITE PEARL



**Résistant aux intempéries**  
ALL WEATHER RESISTANT



**Durable**  
SUSTAINABLE



- ① ALUMINIUM - WHITE - (A2)
- ② ALUMINIUM - CHARBON - (A1)
- ③ ALUMINIUM - LIGHT TAUPE - (A3)
- ④ ALUMINIUM - MOUTARDE - (A7)

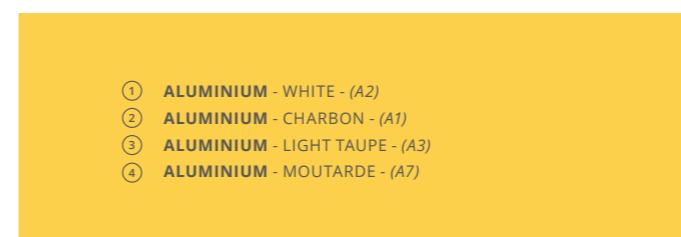



# TECK

TEAK

**MAIORI** est fabriquée à partir de teck durable. Issu de grands arbres à feuillage caduc de forêts mixtes de feuillus, ce bois est apprécié pour sa durabilité et sa résistance à l'eau, ce qui en fait un matériau idéal pour un usage extérieur. Le teck poli bénéficie d'un procédé amélioré de préparation de la surface, grâce auquel les huiles naturellement contenues dans le teck sont amenées en surface.

**MAIORI** selects sustainable teak from a large, deciduous tree in mixed hardwood forests, which is particularly valued for its durability and water resistance, making it ideal for outdoor use. Polished teak has a greater surface preparation technique, where the natural oils within the teak are brought to the surface.

## TECK ( T ) - COULEURS / COLORS



T1 / NATUREL



T2 / VINTAGE BROWN



T3 / VINTAGE GREY



- ① TECK - VINTAGE BROWN - (T2)
- ② TECK - VINTAGE GREY - (T3)
- ③ TECK - NATUREL - (T1)

# OUTDOOR TECHNICAL FABRIC

OTF

**MAIORI** a sélectionné le tissu technique d'extérieur (OTF), matériau le plus performant conçu par le fabricant français Serge Ferrari. Le tissu à base de fibre PVC résiste aux UV et notamment à la décoloration des pigments exposés au soleil. A la fois hydrofuge et résistant au chlore et à l'eau de mer il s'utilise à l'extérieur et intérieur et peut subir des températures extrêmes variant de -30°C (-22°F) à +70°C (158°F). Il est 100% recyclable et ne contient aucune toxine.

**MAIORI** chooses the most rigorous Outdoor Technical Fabric (OTF) from Serge Ferrari. The fabric is made of UV-resistant, mass-coloured PVC fiber that does not fade under the sun. It is water-repellent and resistant to chlorine and seawater. It can be used outdoors, indoors and under extreme temperatures -30°C (-22°F) to +70°C (158°F). It is 100% recyclable and contains no toxins.

## OUTDOOR TECHNICAL FABRIC (F) - PADDED (P) - COULEURS / COLORS

BATYLINE ISO



F12 / JADE



F14 / FERN GREEN

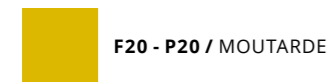

F20 - P20 / MOUTARDE



F10 / LEMON



F11 / ORANGE



F9 / FIRE RED



F17 / NAVY BLUE



F15 / CYAN

BATYLINE ISO

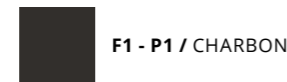

F1 - P1 / CHARBON

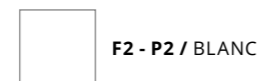

F2 - P2 / BLANC

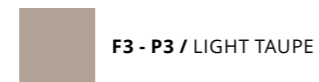

F3 - P3 / LIGHT TAUPE

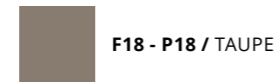

F18 - P18 / TAUPE

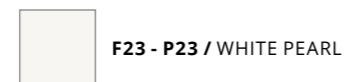

F23 - P23 / WHITE PEARL

BATYLINE LUX



F22 / LUX

BATYLINE EDEN



E6 / GRIS CLAIR



E7 / ARDOISE



E8 / SABLE



Résistant aux intempéries  
ALL WEATHER RESISTANT



Durable  
SUSTAINABLE



# FIBRES PE SYNTHÉTIQUES

## PE SYNTHETIC FIBERS

Cette fibre composite, à l'aspect et au toucher naturels, résiste aux intempéries et aux rayons UV. Grâce à sa résistance chimique et à l'huile ainsi qu'à ses propriétés antimicrobiennes, la fibre Novosier convient parfaitement à une utilisation extérieure comme intérieure.

*A high-end composite fibre with a natural look and feel that is all-weather and UV proof. The fibre's chemical and oil resistance and its anti-microbial properties makes it perfect for outdoor and indoor use.*

### STRAW PE ( F ) - COULEURS / COLORS



WS3 / NATUREL

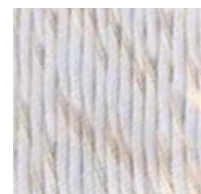

WS5 / WHITE WASH

### WICKER ( W ) - COULEURS / COLORS



WF28 / CHARBON



WF29 / WHITE PEARL



WF30 / LIGHT TAUPE



WF31 / MOUTARDE



WR9 / NATUREL

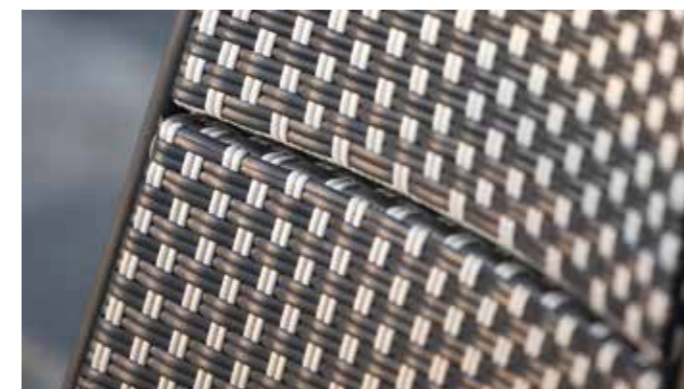
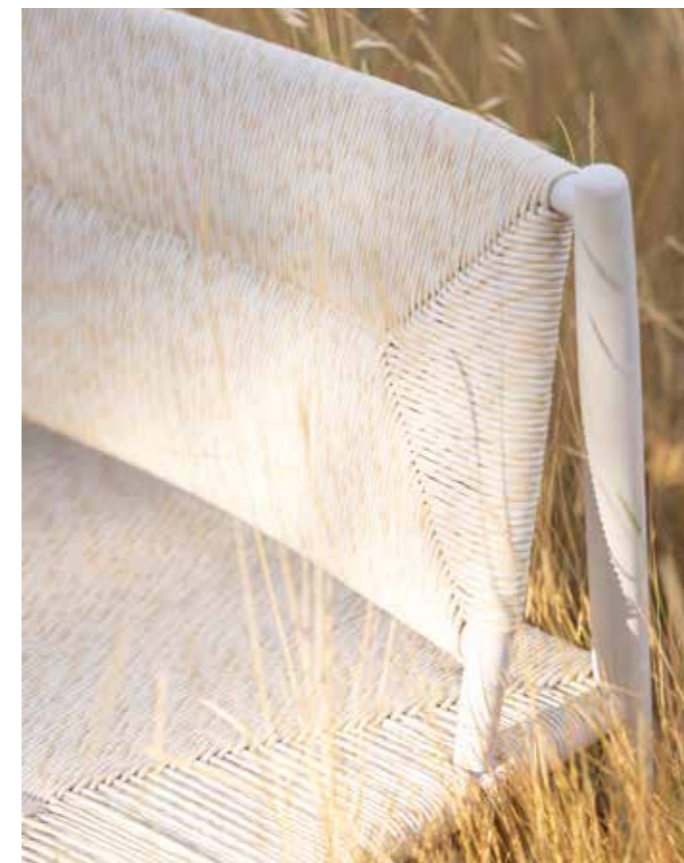

Résistant aux intempéries  
ALL WEATHER RESISTANT



Durable  
SUSTAINABLE

# TOILE OLEFINE

## OLEFIN CANVAS

La toile de Canvas en Olefine est connue pour son étanchéité, sa fiabilité et sa résistance face aux aléas environnementaux : décoloration liée aux UV, moisissure, déformation. Ce textile ingénieux assure un séchage rapide grâce à son traitement hydrofuge.

*Waterproof Olefin Canvas is an advance textile with water repellent treatment to provides quick-dry properties. Its durability, resistance to wrinkling, fading and mildew growth make it favourable for outdoor use.*

### OLEFIN CANVAS ( C ) - COULEURS / COLORS

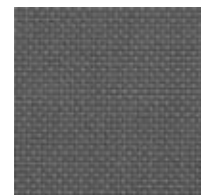

C4 / DARK GREY



C5 / TAUPE

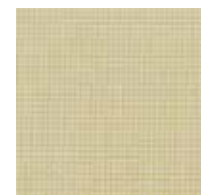

C8 / KHAKI



AT01 / LIN BEIGE



AT02 / LIN GRIS



AT03 / BEIGE



AT04 / MARRON



AT05 / CREME



AT06 / SABLE



AT07 / LAVA STONE

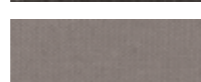

AT09 / GREIGE



AT10 / CAMEL



AT11 / CAFE



AT12 / STONE



**Résistant aux intempéries**  
ALL WEATHER RESISTANT



**Durable**  
SUSTAINABLE



# MAIORI

## UN RAYONNEMENT INTERNATIONAL

A GLOBAL REACH

POUR UNE LISTE COMPLÈTE DE NOS PARTENAIRES, RENDEZ-VOUS SUR LE SITE :

FOR THE FULL LIST OF OUR PARTNERS' SHOWROOMS, VISIT OUR SITE :

MAIORI.COM



### FRANCE

**Biarritz, France** *Hôtel de la Plage*  
**Biarritz, France** *Sofitel*  
**Bora Bora - Polynesie française** *Four Season*  
**Cannes, France** *Film Festival 2019*  
**Cannes, France** *Film Festival 2018*  
**Cannes, France** *Film Festival 2017*  
**Cannes, France** *Le restaurant la Plage Nespresso*  
**Chamonix, France** *Hotel Folie Douce*  
**Corsica, France** *Grand Hôtel de Cala Rossa*  
**Corsica, France** *Sea Lounge*  
**Corsica, France** *Hotel Version Maquis*  
**Île d'Oléron, France** *Thalassa Oléron*  
**La Croix Valmer, France** *Lily of The Valley*  
**Lyon, France** *Maison d'Anthouard*  
**Mandelieu La Napoule, France** *Le Repère*  
**Montagnac, France** *Côté Mas*  
**Paris, France** *Mama Shelter Paris*  
**Paris, France** *Château de Villiers Le Mahieu*  
**Paris, France** *Hôtel Villa M*  
**Paris, France** *Hôtel Brach*

**Paris, France** *Musée Carnavalet*  
**Paris, France** *Hôtel Tours Duo*  
**Paris, France** *Burger Père & fils by Alléno*  
**Paris, France** *Hôtel Méliá*  
**Pontcharra, France** *Château Bayard*  
**Puylobier, France** *Le Relais de Saint Ser*  
**Pyla-sur-Mer, France** *La Co(o)rniche*  
**Roissy, France** *Hôtel Pullman*

### MONDE

**Prague, Czech Republic** *Hotel Mama Shelter*  
**Beirut, Lebanon** *Intercontinental Hotel Mzaar*  
**Beirut, Lebanon** *Skybar Beirut*  
**Dubaï (UAE)** *Cove Beach*  
**Island of Evia** *Club Med Gregolimano*  
**Miami, Florida** *Miami Iron Side*  
**Queensland, Australia** *Oak Beach*  
**Rome, Italy** *Mama Shelter*  
**Sydney, Australia** *Macquarie University*  
**Cambodia** *Mezzanine Roof-Rosewood Phnom Penh*  
**Tokyo, Japan** *Roppongi Hills*

**Tokyo, Japan** *Daito Bunka University*  
**Tokyo, Japan** *Toyo University*  
**Tokyo, Japan** *Harumi Triton Square*  
**Tokyo, Japan** *Yaoko Market Sagami-hara*  
**Tokyo, Japan** *Yaoko Hachioji*  
**Tokyo, Japan** *Yaoko Sakurashi*  
**Osaka, Japan** *AEON Mall Sakai*  
**Hyogo, Japan** *Hotel Seashore Resort*  
**Okinawa, Japan** *Hoshinoya Taketomijima*  
**Okinawa, Japan** *Club Med Ishigakijima*  
**Okinawa, Japan** *Fusaki Resort Village*  
**Okinawa, Japan** *ANA Intercontinental Manza beach resort*  
**Jeju, South Korea** *Jeju Shilla Hotel*  
**Suzhou, China** *Suzhou Taihu Golf Hotel*  
**China** *Enjoyspace Interior*  
**Hong Kong** *The LRC Club*  
**Hong Kong** *Ladies Recreation Club*  
**Hong Kong** *Minh & Kok*  
**Hong Kong** *Simplylife*  
**Singapore** *HBA/Hirsch Bedner Associates*



- ① INTERNATIONAL FILM FESTIVAL - Cannes (France)
- ② ROPPONGI HILLS - Tokyo (Japan)
- ③ LE MÉLIA - Paris (France)
- ④ GRAND HÔTEL DE CALA ROSSA - Corsica (France)

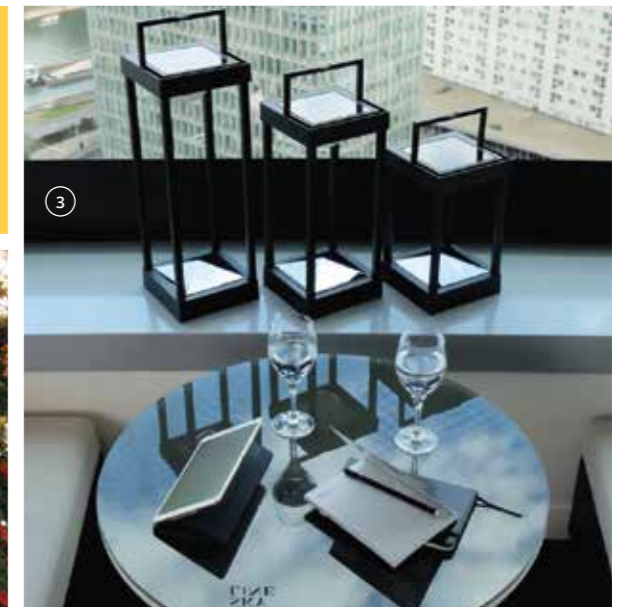



1



3



5



2



4



- ① BURGER PÈRE & FILS BY ALLÉNO - Paris (France)
- ② LA CORNICHE - Pyla (France)
- ③ MIAMI IRON SIDE - Miami (USA)
- ④ NESPRESSO PLAGE - Cannes (France)
- ⑤ HÔTEL VERSION MAQUIS - Corse (France)
- ⑥ LA FOLIE DOUCE - Chamonix (France)



6



1



3



5



7



8

- 1 MINH&KOK - Hong Kong (HK)
- 2 SIMPLYLIFE - Shenzhen (China)
- 3 MAISON D'ANTHOARD - Écully (France)
- 4 SEA LOUNGE - Corse (France)
- 5 MAMA SHELTER - Paris (France)
- 6 OAK BEACH - Australia
- 7 INTERNATIONAL FILM FESTIVAL - Cannes (France)
- 8 COVE BEACH - Dubai (UAE)
- 9 MAMA SHELTER - Paris (France)



4



2



6

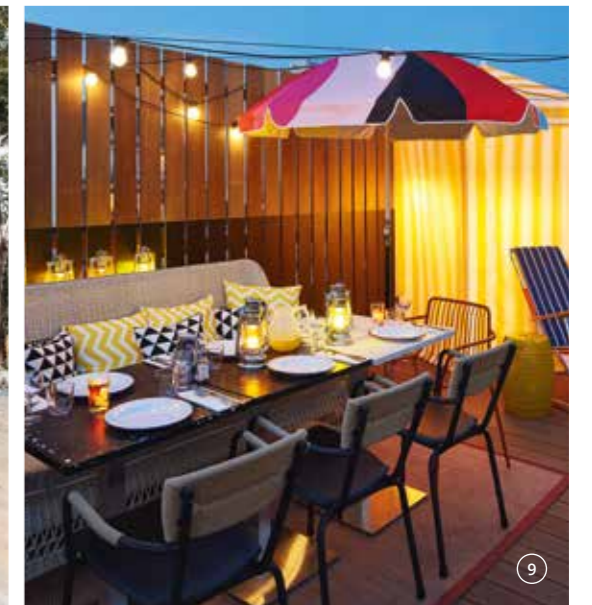

9

## INFORMATIONS TECHNIQUES

TECHNICAL INFORMATION



**Résistant aux intempéries**  
ALL WEATHER RESISTANT



**Durable**  
SUSTAINABLE



**Assemblage requis**  
ASSEMBLY REQUIRED



**Lumière LED**  
LED LIGHT



**Énergie solaire**  
SOLAR POWERED



**Batterie au lithium**  
LITHIUM BATTERY



**USB**  
USB CHARGER



**Bluetooth connecté à l'application MAIORI**  
BLUETOOTH CONNECTED TO MAIORI APP



**Empilable**  
STACKABLE



**Pliable**  
FOLDABLE



**Inclinable**  
RECLINING



**Système modulaire**  
MODULAR SYSTEM



### PHOTOGRAPHIES

Arnaud Childéric / Studio Kalice - [www.kalice.fr](http://www.kalice.fr)

Maiori Design - Morgane Le Gall (p24) - Romain Cabon (p24) - Pierre Monetta (p25)

### STRATÉGIE DE MARQUE & DIRECTION ARTISTIQUE

Carole Lassalle / Espuma - [www.espuma.fr](http://www.espuma.fr)

### GRAPHISME

Fred Renaud / Mokka - [www.mokko.fr](http://www.mokko.fr)

### PUBLISHER

MD Studio - [www.maiori.com](http://www.maiori.com)

### COPYRIGHT

MD Studio  
(All Rights Reserved)

### IMPRESSION

Manufacture d'Histoires Deux Ponts ( France )  
Papier issu de forêts gérées durablement



